

An analysis of Equality and Diversity in a
multinational environment with particular
emphasis on disability

By Antoinette Kenny

A dissertation submitted in partial fulfilment for a BA (Hons) in
Human Resource Management

Barcode No: 39006010322123
Dewey No: 668.3
Date Input: 11/2/09
Price: —

National College of Ireland 2008

Declaration

I hereby certify that this material, which I now submit for assessment of the programme of study leading to the award of B.A (Hons.) in Human Resource Management is entirely my own work and has not been taken from the work of others save and to the extent that such work has been cited and acknowledged within the text of my work

Signed: Antoinette Kenny

Date: 24 July 2008

Student Number: 95003718

Table of Contents

	Page.No.
Chapter 1 – Introduction	4
Chapter 2 – Literature Review	6
Chapter 3 – Research Methodology	25
Chapter 4 – Data and Findings	37
Chapter 5 – Conclusions and Recommendations	50
Chapter 6 – References and Bibliographies	55
Chapter 7 – Appendices	57

Chapter 1 – Introduction

“Disability in relation to a person, means a substantial restriction in the capability of the person to carry on a profession, business or occupation in the State or to participate in social or cultural life in the State by reason of an enduring physical, sensory, mental health or intellectual impairment” (Ref: 2005: Disability Act s2(1))

The Employment Equality Acts 1988 and 2004 prohibit discrimination in the workplace on nine grounds, which include disability. It requires employers to make reasonable accommodations for people with disabilities to access employment, progress their careers and access training, unless this would impose a disproportionate burden on the employer.

This project analyses a multinational organisation in relation to Equality and Diversity, with particular emphasis on disability. This analysis was undertaken in a healthcare company based in Longford called Abbott Diagnostics Division (a member of an American Corporation called Abbott Laboratories). The company will be referred throughout this document going forward as Abbott, which stands for Abbott Diagnostics Division Longford.

Abbott has been named as one of the top 50 Companies to work for in Ireland and whilst this is very positive for the company, in the area of disability Abbott needs to be doing more than just meeting its legal requirements, as the findings from six employees who were interviewed will outline.

The analysis involved interviewing six employees who work in Abbott, asking each individual the same questions, aimed at determining their knowledge in relation to disability and also to determine if the company is taking its responsibility towards people with disability seriously (Ref: Appendices No. 8 – 19).

The findings from the analysis show that the majority of the interviewees are very positive about the culture in the company; however, none of the six employees have any

experience working with a person with a disability in Abbott. Thus begs the question “Is Abbott doing enough with regard to people with disabilities?”

The majority of the interviewees raised concerns about the possibility of a person with a disability working in Abbott due to the fact that the company is tightly regulated. However, on reflection a number of interviewees became more open to the possibility of working with a person with disabilities and identified areas for adjustments to accommodate same.

It is recommended that risk assessments be completed in relation to the different roles in the company and changes to be made to the Job Specifications to accommodate a person with a disability. The risk assessments would initially be a Business Risk Assessment and then upon appointment of a successful employee with a disability, a further risk assessment be completed for that individual.

Whilst the company provides training in the form of Diversity Training and Equality Training to Line Managers, the company needs to be more proactive for people with disability in two areas.

The first area the company can be proactive is to develop a Diversity Policy not just for Abbott Longford but also for Abbott Ireland. Following the implementation of a Diversity Policy, the second area would be with a training and education programme for all its employees to raise awareness of disability.

Chapter 2 – Literature Review

Introduction

As a country, Ireland continues to develop its relationships on both the International and European stage in relation to both economic and social development. This is evident through its membership of the United Nations and the European Union. There are been many developments both economically and socially in Ireland which has lead to changes in the Irish Constitution and the implementation of laws and legislations accordingly. Disability is one of the areas where changes have been made in particular in the area of employment with the introduction of legislation to eliminate discrimination.

Due to these economic and social developments in Ireland, this literature review will discuss the developments, which have lead to changes in Irish laws and legislation arising from Ireland's membership of the UN and EU. These developments have lead to the establishment of the Equality Authority, Equality Tribunal and the National Disability Authority. In the area of legislation the Equality Acts in 1998 and 2004 will be discussed.

This literature review will also outline the advantages and disadvantages of an inclusive workforce arising from findings of the Workway Project, a Project involving IBEC and ICTU aimed at providing a better understanding of disability and a Report by Professor Kathy Monk on behalf of the Equality Authority.

A survey was completed by the CIPD, which analysed diversity in UK organisations and its findings are outlined in relation to diversity in the UK.

Following this, there will also be an introduction to Abbott Ireland Diagnostics Division Longford, its policies and procedures in relation to disability. An analysis will be completed in Chapter 4, which will involve interviewing employees of the company to

determine if the company is taking its responsibility seriously in relation to disability (Ref: Appendices No. 8–19) and recommendations arising from this analysis.

1. International Context – United Nations

The United Nations was founded with the London Declaration of 12 June 1941, while countries were struggling against the invasion of Nazi Germany. Great Britain, Canada, Australia, New Zealand and a number of countries came together and defined a Declaration which stated:

“the only basis of enduring peace is the willing cooperation of free peoples in a world in which, relieved of the menace of aggression, all may enjoy economic and social security”.

(Ref: 1941, The London Charter)

In 1942 Germany invaded the Soviet Union and the US entered World War II. The countries that had signed the London Declaration joined another declaration in Washington, this time joined by the US and the Soviet Union. This declaration was called the “Declaration by United Nations” and each government pledged to employ its full resources, military and economic to defeat Germany, Japan and Italy. The countries also agreed that separate agreements would not be made with the enemy.

The United Nations officially came into existence on 24 October 1945, when China, France, the Soviet Union, the United Kingdom, and the United States had ratified the Charter. The Charter of the United Nations in Appendix No. 1 outlines the main objectives of the United Nations.

The World Health Organisation (WHO) is the coordinating authority for health within the UN system. It is responsible for providing leadership on global health matters, shaping the health research agenda, setting norms and standards, articulating evidence-based policy options, providing technical support to countries and monitoring and assessing health trends.

International Definition on Disability

World Health Organisation defined Disability as:

*“any restriction or lack (resulting from an impairment) of **ABILITY** to perform an activity in the manner of within the range considered normal for a human being”*

(Ref: 1976, WHO)

In 1970 the UN recognised the rights of people with disabilities in the Declaration on the Rights of Mentally Retarded Persons and the Declaration on the Rights of Disabled Person. However, this was criticised for being based on a medical and welfare model of disability. The medical and welfare model of disability is that a person with disabilities are primarily seen as an individual with medical problems, dependent on social security and welfare and also in need of separate services and institutions.

In 1980 these Declarations were revised and have lead to an improved understanding as they relate to people with disabilities. A disadvantage of these Declarations is that they are not legally binding; a Declaration is a statement that does not claim to exclude or modify the legal effects of a treaty.

Over the intervening years, the UN felt that efforts being made by its members to promote full and effective participation and opportunities for people with disabilities in economic, social, cultural and political life were not sufficient and therefore, in 2002 the UN set up a special committee, arising from Resolution 56/168 the UN Convention on the Rights of Persons with Disabilities and the Council of Europe Disability Action Plan 2006 to 2015.

This purpose of this committee is to consider proposals for a comprehensive and integral international convention with the objective to change the thinking about disability from being a welfare concern to a human rights concern.

The purpose of the Convention is to promote, protect and ensure the full and equal enjoyment of all human rights and fundamental freedoms by all persons with disabilities, and to promote respect for their inherent dignity.

2. European Context – European Union

The European Union is based on the rule of law. This means everything it does is derived from treaties, agreed on a voluntary and democratic basis by all Member States. Previously signed treaties have been changed and updated to keep up with developments in society.

Article 6 of the Treaty of the European Union states that the European Union is founded on the principles of liberty, democracy, respect for human rights and fundamental freedoms, and the rule of law principles, common to all member states.

The EU continues to develop and introduce treaties and laws for member states. These treaties define the broad policy goals of the Union and establish institutions with the necessary legal powers to implement these goals; this includes the ability to enact legislation, which can directly affect member states.

A condition of membership is that national courts in member states enforce the EU treaties and the laws. In the case of conflict where EU legislation conflicts with the national law of a member state, the EU is considered to take precedence.

The Treaty of Amsterdam (1997) includes text, which make it possible to combat discrimination, including discrimination on the grounds of disability. The EU also adopted Directive 2000/7/8EC establishing a general framework for equal treatment in employment and occupation. This is reaffirmed in Article 21 of The European Charter of Fundamental Rights the prohibition on discrimination on the grounds of disability.

The Commission is currently working with UN in the preparation of a legally binding instrument, which will reinforce the coherence between International Community and the European Union. This is referred to Resolution 56/168 the UN Convention on the Rights of Persons with Disabilities and the Council of Europe Disability Action Plan 2006 to 2015.

This is an example where the International Community and the European Union is working together to ensure that the rights of people with disabilities are consistent with the rights of an able person.

3. Irish Context

3.1 The Constitution

The Constitution, 1937, is the basic law of the land in Ireland and setting out the fundamental principles that govern our State. The Constitution established the State and its institutions, which forms the guidelines for the Irish legal system and its interpretation by the courts. The Constitution takes precedence over all other sources of law, with the exception of European Law.

The Oireachtas (consisting of Dail Eireann, Seanad Eireann and the President) as stated in the Constitution is the sole law making body in the State as outlined in Article 15.2;

“1° The sole and exclusive power of making laws for the State is hereby vested in the Oireachtas: no other legislative authority has power to make laws for the State.

2° Provision may however be made by law for the creation or recognition of subordinate legislatures and for the powers and functions of these legislatures.” (Ref: 1937, The Constitution, Art 15(2))

This means that changes can be made to the Constitution through legislation, which must be passed by both houses of the Oireachtas, and the President then signs this legislation into Law.

If a common law or a legislative rule conflicts with the provision of the Constitution, it is invalid and has no legal effect. Common law works on the principle of precedent and due to the sheer quantity of common law decisions taken in the courts over the centuries this has led to common law being developed into a body of law.

Article 36 of the Constitution makes provisions for bodies to be established that may exercise judicial functions and powers. Traditionally all employment matters are heard in bodies that are specifically established like the Equality Tribunal and the Labour Court.

As part of this development in the area of employment legislation this has led to the setting up of a number of bodies that specialise in the area of Equality namely,:

- Equality Tribunal
- Equality Authority
- National Disability Authority

The development in legislation with regard to legislation has led to the Employment Equality Acts 1988 and 2004.

3.2 *Equality Tribunal*

The Equality Tribunal is an independent forum that hears and mediates complaints of alleged discrimination under equality legislation. Its decisions and mediated settlements are legally binding. Where the Tribunal upholds a claim for discrimination, it awards redress and it can direct a person to take specific action.

The Equality Tribunal advises that in the six years since the commencement of the Employment Equality Act 1998, a total of 31 cases have been filed with the Tribunal on the disability ground between 1999 and September 2005. It is worth pointing out that 17 of the 31 cases were cases taken against private companies.

3.3 *Equality Authority*

In October 1999 the Equality Authority was set up as an independent body under the Employment Equality Act 1998. The purpose of the Equality Authority is to ensure that discrimination is forbidden under nine grounds; Gender, Marital Status, Family Status, Sexual Orientation, Religious Belief, Age, Disability, Race and Membership of the Traveller Community, in the Employment Equality Act 1998 and 2005 does not occur.

The Equality Authority provides advice and support to a claimant in bringing a claim to the Equality Tribunal but it has no power to decide the case.

3.4 *National Disability Authority (NDA)*

The NDA was established as an independent statutory agency under the Department of Justice, Equality and Law Reform in line with the National Disability Act 1999. The NDA is responsible for ensuring that the rights and entitlements of people with disabilities are protected and also providing advice to the Government on matters concerning people with disabilities.

3.5 *Employment Equality Act 1998 and 2004*

Equality legislation covers employment as well as the provision of goods and services, including education. The Employment Equality Act 1998 introduced the requirement of reasonable accommodation subject to nominal cost exception. This was arising from the

Amsterdam Treaty in 1997 to provide the EU with a new competence to intervene in the area of discrimination; which states:

“Without prejudice to the other provisions to this Treaty and within the limits of the powers conferred by it upon the Community, the Council, acting unanimously on a proposal from the Commission and after consulting the European Parliament, may take appropriate action to combat discrimination on sex, race or ethnic origin, religion or belief, disability, age or sexual orientation.” (Ref: 1997, EC Treaty)

This is an example of how Ireland’s membership of the EU has influenced developments in legislation.

This led to changes in relation to reasonable accommodation in a number of ways and to meet its obligations under the EU Framework Directive, Section 16(3)(a) states that:

“a person who has a disability is fully capable to undertake,any duties if the person would be so fully competent and capable on reasonable accommodation (in this subsection referred to as ‘appropriate measures’) being provided by the person’s employer”. (Ref: European Framework Directive)

Following these amendments in line with the EU Framework Directive, the Equality Act 2004 revised the Equality Act 1998 and together the two Acts are referred to as the Equality Act 1998 and 2005. In some documents it is referred to the Equality Act 1998 and 2004, the President did not sign it into Law until 2005. Their main aim is to promote equality for forbidding discrimination within employment.

Discrimination is described as:

“the treatment of a person in a less favourable way than another person is, has been or would be treated”. (Ref 2004 Equality Act s.4(a))

Under the Act there are nine grounds that discrimination is forbidden within employment and they are Gender, Marital Status, Family Status, Sexual Orientation, Religious Belief, Age, Disability, Race and Membership of the Traveller Community.

3.6 Definitions of Disability in Ireland

Disability is defined as:

“Disability in relation to a person, means a substantial restriction in the capability of the person to carry on a profession, business or occupation in the State or to participate in social or cultural life in the State by reason of an enduring physical, sensory, mental health or intellectual impairment” (Ref: 2005: Disability Act s2(1))

AHEAD, the Association for Higher Education Access and Disability has defined disability further under the following categories

Categories	Type of Disability
i) Blind and Visual Impairment	Albinism and Nyslagmus, Diabetic, Retinopathy, Glaucoma RP
ii) Deaf and Hard of Hearing	Acoustic Neuroma, Deerness, Menieres Disease, Tinnitus
iii) Speech Difficulties	Stammer
iv) Learning Difficulties	Dyslexia, Dyspraxia, Attention Deficit Hyperactivity Disorder, Aspergers Syndrome
v) Physical Disabilities	Cerebral Palsy, Muscular Dystrophy, Spina

	Bifida, Motor Neurone Disease
vi) Medical Difficulties	Multiple Sclerosis, Cystic Fibrosis, Epilepsy Asthma
vii) Mental Health Difficulties	Bipolar Disorder, Manic Depression, Schizophrenia, Obsessive Compulsive Disorder

4. An Inclusive Workplace

One of the key drivers of change in the Irish workplace is workforce diversity and how it is organized. Kandola and Fullerton (1998) defines diversity as:

'The basic concept of managing diversity accepts that the workforce consists of a diverse population of people consisting of visible and non-visible differences including factors such as sex, age, background, race, disability, personality and work style is founded on the premise that harnessing these differences will create a productive environment in which everyone feels valued, where all talents are fully utilized and in which organizational goals are met'.

This diversity includes significant number of people with disabilities remaining outside the workforce despite their capacity to make a significant contribution to an organization with a desire and demand for participation in the workforce.

In an article by Catherine Maguire (2005) called "Understanding Disability" the author writes how

"it has been estimated nearly 40million people in the EU have a disability of which 300,000 of these people live in Ireland. Whilst 11% of the 300,000 people with

disabilities are of working age (i.e. between the ages of 16 and 64), only 36% of these people with disabilities are in employment."

Not only do people with disabilities represent an untapped pool of labour with significant potential, it would provide a copy with the likelihood of including a large proportion of customers with disabilities.

Whilst workplace policies and procedures promote equality of opportunity to accommodate diversity and to combat discrimination the question that must be raised is "Can companies do more in relation to people with disabilities?"

In the same article by Catherine Maguire (2005) called "Understanding Disability", Catherine identifies the reason diversity is important:

'Notwithstanding demographic concerns of an ageing population and a falling birth rate, it is increasingly recognized that in order to move towards a knowledge based competitive economy, it will be necessary to draw on a diversity of talents and perspectives and to improve the participation of a number of groups who have not traditionally participated fully in the workplace.'

IBEC and the Congress of Trade Unions held workshops as part of the "Workway Project" which involved the participation of Employers, Trade Unions representatives and people with disabilities the following were a number of findings arising from the Workway Project:

- A lack of knowledge about disability and where to access the information;
- Education for people with disabilities is focused on coping with their disability as distinct from providing qualifications;
- People with disabilities do not set a career path for themselves, just getting a job is their priority;
- Attitudinal barriers;
- Financial barriers;

- Deficits in pre (or return to) employment preparation training for people with disabilities and;
- A lack of interaction with people with disabilities in the workplace.

According to Ursula Halligan (2007) in an article titled ‘Qualified people with disabilities are able to perform ... the shame is that so few get a chance’; states that

“despite equality legislation, plenty of barriers and prejudices still exist to prevent graduates with disabilities getting work. Unfortunately, the biggest obstacles are often unconscious stereotypical assumptions by some employers who fail to see the potential behind the disability.”

Monk (2007), in her report titled “The Business Impact of Equality and Diversity – The International Evidence” states;

“... the success of equality and diversity initiatives depends on their integration and its culture so that they shape the way in which business is undertaken and the ways in which individuals work”.

Advantages of an inclusive workforce

Monk (2007) in her report titled “The Business Impact of Equality and Diversity – The International Evidence” identifies a relationship between equality, diversity and organizational performance. The top 3 links are as follows:

1. At a strategic level, policies in relation to positive action and equality appear to enhance organizational performance. In addition, there is a relationship between diversity in top team management membership and organizational performance.
2. There is a positive relationship between the adoption by organizations of equality policies and employee outcomes including commitment, job satisfaction, life satisfaction, work-life balance and reduced stress.

3. There are positive employee performance outcomes with reductions in absenteeism, labour turnover, improved employee relations and innovation and creativity arising from the introduction of equality and diversity initiatives.

Disadvantages of an Inclusive Workforce

In February 2007, the Chartered Institute of Personnel and Development (CIPD) commissioned research '*Managing Diversity measuring success*' to explore the challenges involved in measuring the impact of managing diversity and the measures in general use.

This research identified that the negative outcomes of not managing diversity include low morale, ambiguity, conflict and tension, confusion and communication problems. This will lead to undermining the organization and reduce workforce effectiveness and cohesion.

5. Analysis of Diversity in UK organisations

The CIPD undertook a survey in 2006 called "*Diversity in Business: How much progress have employers made? First Findings*"

The key elements of the survey were:

- Drivers for Diversity
- Diversity management: policy and practice
- Diversity Professionals as agents of change
- Key implications and challenges for driving diversity progress

1. Drivers for Diversity

The survey results showed that 68% of UK employers who responded to the survey ranked 'legal pressure' among the top five drivers for managing diversity with 17% of respondent reported the 'business case' as being the most important driver for diversity in

Table 1 What are the key drivers for diversity in your organization?

	Percentage of Respondents
Legal Pressure	68
To recruit and retain best talent	64
Corporate Social Responsibility	62
To be an employer of choice	62
Because it makes business sense	60
Because it is morally right	60
To improve business performance	48

their organizations. Table 1 shows the top 7 responses to the survey.

This demonstrates the importance of developments in law as the main driver for developments in diversity in the UK.

2. Diversity management: policy and practice

Whilst 93% of organizations have a formal diversity policy, many don't cover all the issues addressed by law. The survey found that whilst disability is the diversity issue that is covered in diversity policies, 40% of organizations fail to include disability in their policy. The results from the survey implied that having a 'diversity' policy doesn't necessarily mean that all legal requirements are addressed.

In Point 1 it was good to see how the law has been the main driver for diversity but in relation to policy and procedures the findings are disappointing.

The findings demonstrates that whilst its good to have the law to implement these policies and procedures, the law does not accommodate for organizations not meeting its full requirements. It may be that the UK government should have a governing body who could audit companies to ensure compliance with the law and failure to do so would result in fines.

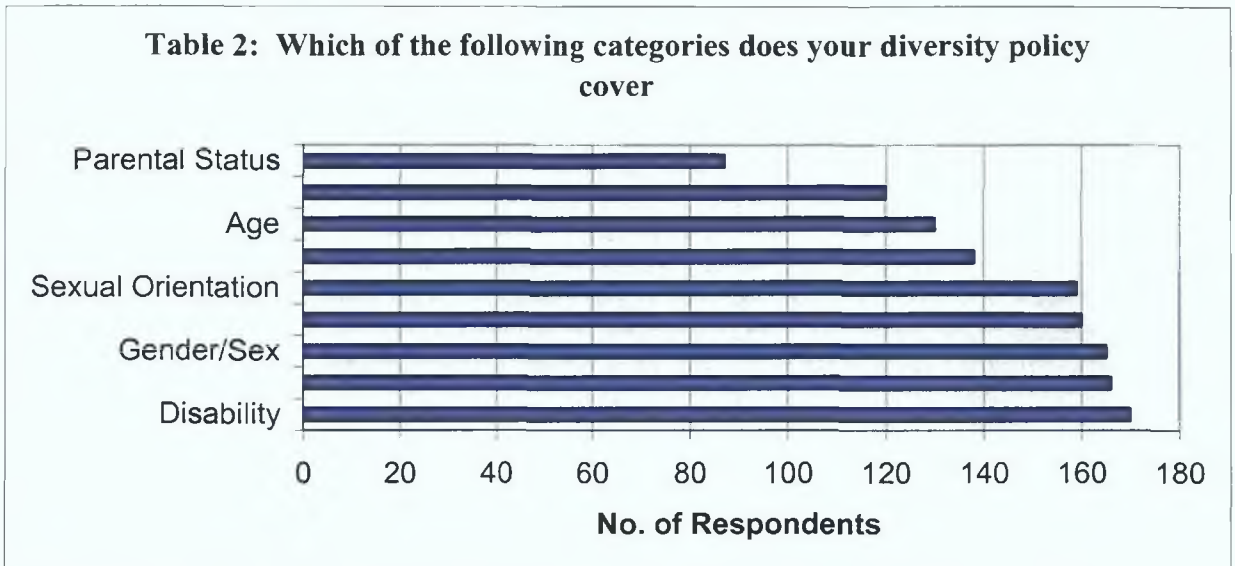

3. Diversity professionals as agents of change

The survey found that the importance of ownership for diversity decreases by level of authority. The survey results suggest that its only when organizations recognize and communicate the real value diversity adds to business that they prioritise it and get senior management support and commitment to help progress.

The findings suggest that individuals who are responsible for managing diversity are doing so as part of another role, with limited resources and capital coupled with a lack or power or influence to initiate organization change.

This again demonstrates that implementation in relation to diversity becomes diluted and without Senior Management support, this will not progress. The matter in relation to Senior Management support is discussed in the findings from this Project as this is key to the success of any initiative.

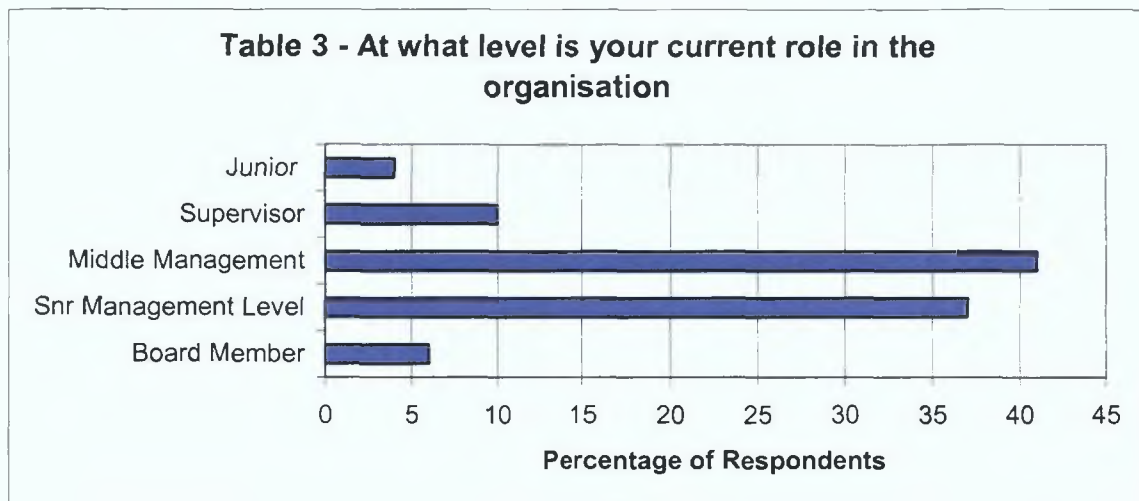

4. Key implications and challenges for driving diversity progress

The findings from the CIPD survey is as follows;

“it is clear that more attention needs to be paid to communicating messages about the importance of managing diversity. It is also important to provide information, support and guidance to help organizations to get to grips with making progress in this challenging area that will bring advantages to people, business and society. The evidence from the survey is that this is crucial given the under-investment by organizations in dedicated resources to progressing diversity.”

Due to the economic changes in the World, which impact every country, including the UK, it is important for organizations to embrace diversity to remain competitive in an ever increasing competitive economic market.

As discussed later, it is important for a company like Abbott to embrace diversity further by introducing a Diversity Policy that enhances its business and not just meets the legal requirements. The recommendations in relation to this subject will be discussed later.

6. Organisation Context

Dr. Wallace Abbott in Chicago founded Abbott Laboratories in 1888. The business began due to Dr. Abbott's dissatisfaction with medical preparations that were available at the time. His business became so successful that other doctors began ordering from him and he set up a company, known today as Abbott, to meet this demand. Abbott Laboratories is a broad based healthcare company that discovers, develops, manufactures and markets products and services from prevention to diagnosis of treatment care.

Abbott Ireland Diagnostics Division (AIDD) is a subsidiary of Abbott Laboratories, which today is a global diversified healthcare Corporation, employing over 55,000 people in over 140 countries. Abbott Ireland is one of the largest overseas subsidiaries of the company and its headquarters is in Sligo with seven manufacturing locations and three support operations.

In 2003 Abbott Laboratories announced a €115 million investment in its diagnostics division in Ireland, which led to the expansion of the existing Diagnostics facility in Sligo and the building of a new Greenfield site in Longford.

The Longford facility manufactures 27 diagnostic reagent products, which are used in the early and acute detection of a medical condition, which can lead to effective medical treatment. The product portfolio includes kits for Thyroid, Fertility & Pregnancy, Cardiology, Therapeutic and Metabolic Drug Monitoring. These products are used on various Abbott Instruments including AxSym, IMX and Architect platforms and these instruments are used in various clinical environments including hospitals, reference labs and blood banks.

The preparation and filling of these reagents takes place in a clean room environment under stringent GMP and GLP controls. The environment in which the reagents are manufactured is ISO9001:2000 credited.

Abbott's diversity statement is as follows:

"We value diversity at Abbott – in our people, products, technologies and markets. Diversity is a key component of our business strategy, because we know the different perspectives and insights that our employees offer allow us to better understand and connect with the people we serve".

The company is committed to equal opportunity of employment and all employment decisions are based on merit, qualifications and abilities. The company endorses a working environment that is free from discrimination, harassment and sexual harassment and this is event through its Policies and Procedures, which are as follows:

- Recruitment Policy for Abbott Ireland
- Bullying and Harrassment Policy for ADDLF
- Grievance Procedure for ADDLF
- Dignity at Work Charter at ADDLF

The Core Competencies for all employees in the company are Teamwork, Adaptability / Flexibility, Initiative and Integrity.

The company also provides training in the form of HR Clinics, which informs the Line Managers of the company's policies, and procedures in a day-to-day manufacturing environment. As part of these HR Clinics, Managers are trained on Equality Legislation and Diversity Training.

Abbott has been named as one of the top 50 Companies to work for in Ireland and whilst this is very positive for the company, there are a number of things that the company can do to maintain this position and particularly in the area of disability.

To facilitate this, an analysis of Abbott, which involved interviewing six employees. These six employees were asked the same questions that were designed to determine their knowledge of disability and also to determine if the company is meeting more than its legal obligations towards people with disability. As part of this analysis recommendations and conclusions are given arising from the feedback of these interviews (*Ref: Appendices No. 8 – 19*).

Chapter 3 Research Methodology

Easterby-Smith et al. (2002) argue that three things combine to make business and management a distinctive focus for research:

- the way in which managers (and researchers) draw on knowledge developed by other disciplines;
- the fact that managers tend to be powerful and busy people. Therefore, they are unlikely to allow research access unless they can see personal or commercial advantages;
- the requirement for the research to have some practical consequence. This means it either needs to contain the potential for taking some form of action or needs to take account of the practical consequences of the findings.

1. Primary Data Research

There are many different approaches to research and in order to determine the approach for a particular topic it is important to identify the steps taken to carry out research on this particular topic.

When dealing with a topic such as disability and analysing a company in relation to their approach to disability, it is important to remain sensitive to the topic but to equally provide a balanced view in relation to the analysis.

In researching the topic, the Internet was the first step due to the immense amount of information available. The NDA website provided a lot of detail in relation to reports and research on the developments with regard to disability and the IBEC website provided research in relation to employment and people with disabilities.

CIPD also provided a valuable source of information with regard to developments in the UK in relation to diversity coupled with providing a questionnaire to assist in

determining “*how does an organisation treat disabled employees and customers*”, which forms part of the recommendations of this Project with the author recommending that elements of this questionnaire can be used to develop a template in relation to determine if the company is doing enough for people with disabilities.

Following the progress of legislation it was important to provide detail in relation to research which has been completed with regard to diversity and in particular disability in the area of employment particularly from an international prospective.

It was important to link the literature review to the research methodology to determine the purpose of the Project and this was done from interviewing a number of employees, asking them questions being mindful of the ethical debate to determine was Abbott taking its responsibility seriously towards people with disability or could the company be doing more.

2. Ethical Issue

The subject for this Project is centred around the subject of Disability which is a very sensitive subject and the questions when drafted was to ensure that the interviewee did not feel uncomfortable answering the questions, therefore the questions asked were open questions with the exception of one question.

This question was a closed question, asking the interviewees if they had an experience working with a person with disabilities, as this information was a key part of the analysis. None of the interviewees appeared to be uncomfortable answering the question.

The interview questions, outlined later, define disability under a number of different headings e.g. blind and visual impairment, deaf and hard of hearing, etc., and each interviewee reading the definitions and were given the opportunity to reflect on whether a person with one of these disabilities could perform a role in the company.

At different points during a number of interviews, the interviewees were looking at the definitions in relation to roles in the company and determining if a person with a particular disability would be able to perform certain tasks.

As part of the findings from this Dissertation, Job Specifications are to be reviewed with regard to the key responsibilities of each job. It will be recommended that a professional external body, qualified in the area of requirements of people with disabilities, assess the requirements of each role in the company and advise the company of changes required to accommodate a person with a disability. This would ensure an objective overview is taken in relation this assessment.

3. Process Steps

In order to determine the research method, the methods considered were surveys, questionnaires and interviews from both qualitative and quantitative approach.

From a Quantitative prospective it would require a large group of population to take part in a questionnaire or survey and this is used to test hypotheses, the data from this method is specific and precise. The second method considered was a Qualitative method which involves a smaller group of people and is used to gain an understanding of social and human activity.

In order to determine if Abbott is doing more than its legal requirement in relation to people with disabilities, a Qualitative method of research would be the most effective due to the sensitivity of the subject matter being discussed and also to provide the best source of information.

Once the interview questions were finally drafted, the question was raised as to what employees would be selected to interview in relation to the Project. The interviewer selected the interviewees (Section 4 of this Chapter outlines the Interviewee's reason for

selecting each interviewer) and advised the HR Manager on the site of the employees selected. The HR Manager agreed with the interviewer based on the reasons listed in Section 4, that the employees selected would be right to facilitate the collection of data for the Project.

Once selection of the employees was completed, the interviewer considered the process for the interview format and the reason for the interview format outlined in Section 5.

3.1 Drafting of Interview Questions

The Interview Questions were developed over a number of weeks and changes were made to the Interview Questions during this time. Whilst the first draft of interview questions was shown to the HR Manager and feedback taken on board, further amendments to the interview questions took place following more research on the topic of disability.

3.2 Draft 1 – Interview Questions (Ref: Appendix No. 2)

The interview questions outlined in Figure 1 was the initial draft of questions to provide the research data for the dissertation.

Figure 1 - Draft No. 1

Interview Questions

Tell me about Equality and Diversity in ADD Longford
What has been your experience with disability in the company
How do you feel it works or does not work
What do you think we should do differently

Question one, *“Tell me about Equality and Diversity in ADD Longford)”* was an introductory question which was aimed to get the employee thinking in relation to Equality and Diversity within the company and to put at ease in relation to the interview.

Question two, *“What has been your experience with disability in the company”* was incorrect and changed as the interviewer felt it would not provide enough detail about the company

Question three, *“How do you feel it works or does not work”* was revised for the same reason as question two.

Question four *“What do you think we should do differently”* was revised and rephrased as the interviewer felt that the question was open to interpretation and some Interviewees may view the question as a more personal question rather than from a company context..

3.3 Draft No 2 Interview Questions (Ref: Appendix No. 3)

Figure 2 outlines Draft No. 2 of the Interview Questions for this Dissertation

Figure 2 – Draft No. 2

Interview Questions

Title of Dissertation: An analysis of Diversity within a multinational company with particular emphasis on disability

Tell me about Equality and Diversity in ADD Longford

Disability can be defined under the following headings:

Are you familiar with the definitions for Disability?

What has been your experience working with people with disability in the company

Do you feel the company takes its responsibility seriously in relation to people with disability?

What do you think the company should do differently

In Draft No 2, the following changes were made to the interview questions: The interviewer included the Title of the Dissertation to give the Interviewees a better understanding of the purpose of the Interview.

Question one remained unchanged.

Question two, "*Disability can be defined under the following headings:*

Are you familiar with the definitions for Disability?" was amended to introduce the interviewee to the definitions and the question was to determine the level of familiarity with these definitions.

Question three was changed to, "*What has been your experience working with people with disability in the company*", this was a direct question which was aimed at determining what experiences the interviewees had with working with people with disability in the company

The wording of Question four was changed to, "*Do you feel the company takes its responsibility seriously in relation to people with disability?*" sought to encourage the interviewees opinion on how they felt the company approaches its responsibility towards disability.

Question five was altered to state, "*What do you think the company should do differently*", these sought opinions from the interviewees on where the company could improve in relation to people with disabilities.

3.3 Draft No 3 Interview Questions (Ref: Appendix No. 4)

Figure 3: Draft No. 3 of the Interview Questions

Figure 3 – Draft No. 3

Interview Questions

Title of Dissertation: *An analysis of Diversity within a multinational company with particular emphasis on disability*

*Tell me about Equality and Diversity in ADD Longford
Disability can be defined under the following headings:*

a)	<i>Blind and Visual Impairment</i>	<i>(Albinism and Nyctalopia, Diabetic Retinopathy, Glaucoma RP)</i>
b)	<i>Deaf and Hard of Hearing</i>	<i>(Acoustic Neuroma, Deafness, Menieres Disease, Tinnitus)</i>
c)	<i>Speech Difficulties</i>	<i>(Stammer)</i>
d)	<i>Learning Difficulties</i>	<i>(Dyslexia, Dyspraxia, Attention Deficit Hyperactivity Disorder, Aspergers Syndrome)</i>
e)	<i>Physical Disabilities</i>	<i>(Cerebral Palsy, Muscular Dystrophy, Spina Bifida, Motor Neurone Disease)</i>
f)	<i>Medical Difficulties</i>	<i>(Multiple Sclerosis, Cystic Fibrosis, Epilepsy, Asthma)</i>
g)	<i>Mental Health Difficulties</i>	<i>(Bipolar Disorder, Manic Depression, Schizophrenia, Obsessive Compulsive Disorder)</i>

*Are you familiar with the definitions for Disability?
What has been your experience working with people with disability in the company
Do you feel the company takes its responsibility seriously in relation to people with disability? Can you give examples?
What do you think the company should do differently*

In Draft No 3 many of the questions remained the same except Question 2 outlines the definitions of Disability, which was not outlined in Draft No. 2

3.4 **Draft No. 4 Interview Questions** (Ref: Appendix No. 5)

Figure 4: Draft No. 4, the Interview Questions remained unchanged.

Figure 4 – Draft No. 4

Interviewer: *Antoinette Kenny*

Interview No.: _____

Date: _____

Title of Dissertation: *An analysis of Equality and Diversity within a multinational company with particular emphasis on disability*

Interview Questions

*Tell me about Equality and Diversity in ADD Longford
Disability can be defined under the following headings:*

<i>a) Blind and Visual Impairment</i>	<i>(Albinism and Nyslagmus, Diabetic Retinopathy, Glaucoma RP)</i>
<i>b) Deaf and Hard of Hearing</i>	<i>(Acoustic Neuroma, Deafness, Menieres Disease, Tinnitus)</i>
<i>c) Speech Difficulties</i>	<i>(Stammer)</i>
<i>d) Learning Difficulties</i>	<i>(Dyslexia, Dyspraxia, Attention Deficit Hyperactivity Disorder, Aspergers Syndrome)</i>
<i>e) Physical Disabilities</i>	<i>(Cerebral Palsy, Muscular Dystrophy, Spina Bifida, Motor Neurone Disease)</i>
<i>f) Medical Difficulties</i>	<i>(Multiple Sclerosis, Cystic Fibrosis, Epilepsy, Asthma)</i>
<i>g) Mental Health Difficulties</i>	<i>(Bipolar Disorder, Manic Depression, Schizophrenia, Obsessive Compulsive Disorder)</i>

*Are you familiar with the definitions for Disability?
What has been your experience working with people with disability in the company
Do you feel the company takes its responsibility seriously in relation to people with disability? Can you give examples?
What do you think the company should do differently?*

However, the following additions to the document:

Interviewer: Antoinette Kenny

This remained unchanged for all interviews as Antoinette Kenny completed all interviews over a number of days

Interview No: This was completed at the time of the Interview as each Interview was numbered and this number relates to the person that was interviewed. The information in relation to the interviewee is contained in Appendix No. 6 but this information is confidential and for Examiner purposes only, should the details of the interviews need to be checked.

Date: This was the date the Interview was completed and this was handwritten on the document on the day the interview took place.

As outlined above, there were no amendments made to the questions in Draft No. 4

3.5 Draft No. 5 – Interview Questions (Ref: Appendix No. 6)

Having completed two interviews on 18 June 2008, the interviewer identified a spelling error on the document; the word deaf was spelt incorrectly as dear. This was amended in Draft No. 5 and Draft No. 5 in Appendix No. 5 was used for the remainder of the interviews.

4. Interviewee Selection Process (Ref. Appendix No. 7)

It was important to select employees from different areas of the business, with different levels of experience and qualification and also different service levels. The interviewees selected are profiled as follows:

4.1 Interviewee No. 1

Interviewee one works in the company as a General Operator and they have a leaving certificate qualification. The interviewee is very experienced having worked in manufacturing companies in the local area for 10+ years and would have achieved an EE+ (Exceed Expectations – the highest performance rating) on their Annual Performance Appraisal and is a key member of the Team.

Interviewee One was one of the first hires into the role they work and played a vital role in setting up the area they currently work in. The interviewer felt that this interviewee was experience and based on their previous experience would provide recommendations.

4.2 Interviewee No. 2

Interviewee Two was a graduate and had joined the company straight from academia. The interviewer felt that although interviewee no. 2 had joined the company with less than two years interview experience, the interviewer wanted to get feedback from an employee with less experience than Interviewee No. 1 to ensure a balanced approach.

4.3 Interviewee No. 3

Interviewee Three joined the company approximately 4 years ago having completed a PhD and the interviewee and had also joined industry straight from academia, having studied a PhD.

The interviewer felt that this interviewee would be challenging as from experience working and recruiting PhD students, these students do not like to give their opinion without scientific facts to back them up. It is worth noting that prior to the interview, this interviewee was the only one who wanted to know if the interviewer required them to do some preparation for the interview.

The interviewer advised that no preparation was required prior to the interview as it would be difficult to assess the level of preparation each interviewee did on the subject.

4.4 Interviewee No. 4

Interviewee four was also a PhD student but had previously worked in another Department in the company and the interviewer picked this employee based on their experience to date. This interviewee, like Interviewee three, had come straight from academia having studied a PhD with less industry experience than Interviewee No. 3. This interviewee was identified in the company as Key Talent and a possible employee for development for the future based on performance to date.

4.5 Interviewee No. 5

The reason for selecting this interviewee was that this employee worked in a people management role in Abbott and had many years experience working in the healthcare industry which included people management roles prior to joining Abbott. The interviewer felt that this employee would give constructive feedback in the interview.

4.6 Interviewee No. 6

The reason for selecting interviewee six was that the interviewee is a member of the Senior Management Team and has been involved in many projects, which have promoted the company. Also, like interviewee 5, interviewee six had worked in senior roles in other healthcare company and again the interviewer felt that this interviewee would provide positive and constructive feedback in the interview.

5. Interview Format

The Interviewees were interviewed separately, the interviews had a semi-formal structure and each interview lasted between 20 to 30 minutes. The interviews took place in a private room that is used for interview purposes at the Longford facility over a three-day period. There were no interruptions during the interview and the atmosphere in the room was relaxed.

An explanation was given at the beginning of each interview as to the reason the interview was taking place. The seating arrangements placed the Interviewee beside the interviewer who read out the questions and the question sheet was visible at all times. As answers were given, the interviewer transcribed the answers onto the Interview sheet. Clarification was sought as required and answers were read back to the Interviewee and an opportunity was given to the Interviewees to expand or amend their answers.

The interviewee felt that a formal approach was the best approach as this was more suited to the company culture. The culture within the organisation is that meetings and interviews were to be formal with full preparation to be completed by the person chairing the meeting or conducting the interview. As all employees were familiar with this format, the interviewer felt that as the interview questions were to determine the company's approach to people with disabilities, the employees would feel most comfortable with this approach.

Abbott has been named as one of the top 50 Companies to work for in Ireland and whilst this is very positive for the company. There are a number of things that the company can do to maintain this position and particularly in the area of disability as the findings from six employees who were interviewed will outline.

1. Data Analysis

In order to ascertain if Abbott, as a company, is meeting more than its legal requirements with regard to people with disability, data has been compiled following interviews (*Ref: Appendices No. 8 – 19*) with six employees of the company.

The legal requirements are in relation to people with disability, the Employment Equality Acts 1998 and 2004 states that under the Act there are nine grounds that discrimination is forbidden within employment and they are Gender, Marital Status, Family Status, Sexual Orientation, Religious Belief, Age, Disability, Race and Membership of the Traveller Community.

Abbott currently has policies, procedures and training programmes to ensure that discrimination is forbidden in the company on the nine grounds listed under the Act, referred to above.

The policies and procedures which all employees work with are the Recruitment Policy for Abbott Ireland, Bullying and Harrassment Policy for Abbott, Grievance Procedure for Abbott, Dignity at Work Charter at Abbott along with a Diversity Statement.

As outlined in the company handbook (2007):

“The company is committed to, equal opportunity of employment and all employment decisions are based on merit, qualifications and abilities. The company endorses a working environment that is free from discrimination, harassment and sexual harassment”

This is also event in the company's policies and procedures.

It is positive to note that the company have these policies, procedures and training programmes to ensure that discrimination is forbidden under the Employment Equality Acts 1998 and 2004.

As outlined above the purpose of this Dissertation is to provide an analysis in relation to Equality and Diversity in Abbott with particular emphasis on disability and to provide the data for this analysis, six employees at the company were interviewed over a number of days, Figure 1 overleaf, outlines the Draft No. 5 (*Ref Appendix No. 6*) of the Interview Questions which were asked of the six employees and the findings from these interviews were as follows:

1.1 Question One (Ref: Appendices No. 8 – 19)

This question was an introductory question with the aim to get the Interviewee to start thinking about Equality and Diversity in Abbott. The general consensus amongst the group of interviewees was that Abbott has a positive culture towards Equality and Diversity. A number of the interviewees discussed the equal division of male/female employees and the number of employees that are working in the company that are not originally from Ireland.

The interviewees with people management responsibility who take part in the Recruitment and Selection process in the company felt that the company provides adequate training to employees to ensure that the company does not discriminate against both employees and members of the public.

1.2 Questions Two (Ref: Appendices No. 8 – 19)

Question Two outlined the definitions of disability under 7 different headings and each interviewee was asked if they were familiar with the definitions, this was to determine the level of awareness amongst the Interviewees of disability. Four of the interviewees (Interviewee One, Two, Five and Six) were aware of definitions with regard to disability but would not be able to advise of all seven prior to the interview.

The third interviewee was familiar with most of the definitions but like the fourth interviewee, who was not familiar with the definitions, the interviewee advised that when disability is mentioned, one automatically assumes it is a person with a physical disability. This is quite common amongst people that when you mention people with disabilities, one automatically assumes it is a person in a wheelchair, yet as outlined in the interview questions, there are many definitions of disability.

Figure 4 – Draft No. 5

Interviewer: *Antoinette Kenny*

Interview No.: _____

Date: _____

Title of Dissertation: *An analysis of Equality and Diversity within a multinational company with particular emphasis on disability*

Interview Questions

Tell me about Equality and Diversity in ADD Longford Disability can be defined under the following headings:

- | | | |
|-----------|------------------------------------|--|
| <i>h)</i> | <i>Blind and Visual Impairment</i> | <i>(Albinism and Nyctalopia, Diabetic Retinopathy, Glaucoma RP)</i> |
| <i>i)</i> | <i>Deaf and Hard of Hearing</i> | <i>(Acoustic Neuroma, Deafness, Menieres Disease, Tinnitus)</i> |
| <i>j)</i> | <i>Speech Difficulties</i> | <i>(Stammer)</i> |
| <i>k)</i> | <i>Learning Difficulties</i> | <i>(Dyslexia, Dyspraxia, Attention Deficit Hyperactivity Disorder, Aspergers Syndrome)</i> |
| <i>l)</i> | <i>Physical Disabilities</i> | <i>(Cerebral Palsy, Muscular Dystrophy, Spina Bifida, Motor Neurone Disease)</i> |
| <i>m)</i> | <i>Medical Difficulties</i> | <i>(Multiple Sclerosis, Cystic Fibrosis, Epilepsy, Asthma)</i> |
| <i>n)</i> | <i>Mental Health Difficulties</i> | <i>(Bipolar Disorder, Manic Depression, Schizophrenia, Obsessive Compulsive Disorder)</i> |

Are you familiar with the definitions for Disability?

What has been your experience working with people with disability in the company Do you feel the company takes its responsibility seriously in relation to people with disability? Can you give examples?

What do you think the company should do differently?

1.3 Question Three (Ref: Appendices No. 8 – 19)

This question was to determine if any of the interviewees had experience working with people with disability in Abbott. It is worth pointing out at this stage, that a person with a disability has no obligation to advise their Employer of their disability, people with disabilities are encouraged to advise Employers of their disability to ensure that a reasonable accommodation can be made to facilitate the person with the disability (Ref: *Equality Act 1998 and 2005*).

However, at Abbott all prospective employees must undertake a medical and this information forms part of the medical questionnaire and as part of the medical questionnaire, candidates are asked about their medical history.

There are two definitions of disabilities i.e. Medical Difficulties and Mental Health Difficulties, which are not overtly noticeable and if a Team Leader / Manager had an employee on their team with one of these disabilities, the Team Leader / Manager would be aware that the employee may have certain restrictions in relation to completing a particular function of their role or may need extra breaks, etc. The details in relation to the disability would be confidential information between the Occupational Health Advisor, Company Doctor and Employee.

Whilst an employee is encouraged to discuss the matter with their Line Manager, in the event that they may require special circumstances in the form of breaks, etc. there is no obligation on the employee to tell their Manager.

There were two interviewees that had people management responsibilities in the company. Of the six interviewees that were interviewed, all six interviewees had no experience working with a person with disabilities under the definitions outlined. One of the Interviewees advised that whilst there is no employees currently on their team with a

disability that they were of a prospective employee who will be joining his team with a disability under the definition of medical difficulties.

1.4 Question Four (Ref: Appendices No. 8 – 19)

Question Four was to determine if the Interviewees felt the company took its responsibilities towards people with disabilities seriously.

Interviewee one advised that as they had no experience working with people with disabilities, however, they are sure, from their knowledge and experience working in the company along with the positive culture within the company, that the company takes its responsibility seriously.

Interviewee two was sure that the company takes its responsibility seriously and it was surprising to note, that the Interviewee felt that if they had sustained a disability during employment with Abbott (albeit outside of the company), the Interviewee was confident that the company would accommodate them. It was interesting to note that this was the same feedback from Interviewee Four also. This is positive feedback about the company and how it treats its employees.

Interviewee three, four and five outlined that the company had disabled parking, disabled toilets and a lift to accommodate people with disabilities however, interviewee six was unsure if that was a legal requirement and if so, it demonstrated that Abbott Diagnostics Division met its legal obligations to people with disabilities.

Interviewee three and six was unsure if the company had any policies in relation to people with disabilities. Interviewee six advised that disability has not been discussed at any meetings that he was a party to however, if the company provided training and made employees aware of disability, the positive culture within the company would ensure that disability would be taken seriously.

Interviewee four and five advised that until they have experience working with a person with disabilities, the interviewees were unable to assess if the company takes its responsibility seriously.

Arising from this question, there is a very positive message coming from this question in that three Interviewees felt that the culture within the company is positive in the event that if the Interviewees suffered a disability arising from an accident, the three Interviewees would feel confident that the company would support them in their roles with the company.

An interesting point was made by interviewee six, the company had disabled parking, disabled toilets and a lift, was the company only meeting the legal requirements and should more be done by the company to accommodate people with disabilities.

In response to the point raised by interviewee six, the Building Regulations outlined by the Department of the Environment 2000 (*Ref: Appendix No. 20 Building Regulations*) states the following requirements for access for people with disabilities:

1. Adequate provision shall be made to enable people with disabilities, to safely and independently access and use a building.
2. An accessible entrance should be designed and constructed (requirements outlined in guidelines)
3. Circulation within the building refers to the opening width of doors, etc. Section 1.12 of Building Regulations states;
"A suitable passenger lift should be provided to any storey above or below the entrance storey..."
4. Use of facilities in the building should be so designed and constructed as to allow for independent circulation by people with disabilities and independent access to the range of services and facilities provided on each storey of the building.

This demonstrates that the company is meeting its legal requirements by providing car parking spaces, disabled lift and disabled toilets.

1.5 Question Five (Ref: Appendices No. 8 – 19)

This question was designed to ascertain if the company should be doing things differently in relation to people with disability. It is interesting to point out that at this stage in the interview, all six Interviewees were thinking about people with disabilities and looking at their own jobs from the perspective of a person with a disability doing the job.

Whilst this may not be ethical, each Interviewee was looking at the definitions under disability and discussing openly if a person with a particular disability could do the job and the limitations a person with a particular disability would have in relation to particular positions.

As a healthcare company, the Irish Medicines Board and ISO regulate Abbott and question five was designed to challenge the Interviewees to “think outside the box”.

Interviewee one made a surprising comment when answering the question by stating that they did not find the Abbott website user friendly and didn't apply for their current position until it was advertised on local radio. Abbott uses the website for all its advertising of positions and this is good feedback in relation to how the company advertises positions. This may be one of the reasons why the company has not received any applications from people with disabilities.

Interviewee one suggested that the company should review how it advertises its positions to ensure that applications are received from a wider pool of applicants and this was echoed by all of the Interviewees. On reflection, Interviewee One advised that with a number of minor adjustments to their current role, people with disabilities outlined under the seven definitions (i.e. blind and visual impairment, deaf and hard of hearing, etc.)

would be able to work in certain areas of the Operations area the Interviewee currently works.

It was interesting to note that interviewee two recommended, as part of the review of the Job Specs, an extra section to be added to the company's official Job Specification template to detail the tasks that are carried out for each role in the company for example; a Diagnostic Technologist works in the laboratory but the role also involves paperwork. The interviewee suggested that the section on the Diagnostic Technologist Job Specification would state that the role involves 70% lab work and 30% desk work.

It is worth noting at this stage that with the current Recruitment Database, the opportunity to put this on the advertisement is already in existence but may not be used by all of the Talent Acquisition Team (this is the team who are involved in the recruitment and selection process for all Abbott sites). The amendment to the Official Template of a Job Specification would require sign-off by Senior Management.

Interviewee three recommended that the company educate employees in relation to disability and to review how the company advertises jobs. Interviewee five recommended that the company look at the different jobs in the company and to assess the different responsibilities of each role against the different definitions of disability and also recommend that the company do a risk assessment in relation to people with disability under each definition against the main tasks that are carried out by a particular role.

As part of the education of employees in relation to disability, all interviewees were aware of the sensitivity in relation to people in disability and the message from all the interviewees is that whilst they would have no problem working with people with disability it is important for the company to provide guidelines and training for employees to ensure that people with disabilities were treated with respect and dignity in the workplace.

Interviewee six who requested the company to put a system in place or provide guidelines to employees in relation to disability reiterated this.

4. Software Change

As discussed above the company has a positive culture in relation to their employees where a number of the Interviewees felt confident, if they had a personal disability, the company would accommodate them in their role.

The interviews provided positive feedback by all Interviewees with regard to the opportunity to work with people with disabilities however, a number of interviewees requested that the company provide training to all employees when appointing a person with a disability to ensure that the person with disability was treated with respect and dignity.

It was recommended that risk assessments be completed from a business and individual perspective in-line with the definitions of disability to determine if reasonable accommodation can be made by the company to accommodate a person with a disability.

As was recommended by interviewee two the assessment in relation to the roles of each Job function in the company would need to be completed by a professional external body, experienced in this area and this assessment would be done in conjunction with the relevant Team Leader / Manager for each job function.

Following this assessment, as outlined by most of the interviewees the Job Specifications would need to be amended arising from the findings of the risk assessment and more detail to be provided with regard to the specific tasks of a particular job for example, a Diagnostic Technologist works in a Laboratory and the roles involves 70% laboratory work and 30% desk work.

As suggested by Interviewee two there could be a section added onto the Job Specification which could say: **This role involves the following**with approximately 3 lines detailing the most regular tasks that are required for the role.

Whilst the company has a positive culture, it is important for the company to continue this and whilst there are many suggestions in how this can be done. In the area of disability, it would be recommended that the company educate employees in relation to disability and to provide guidelines for employees in the day to day interaction with people with disabilities to ensure that the sensitivities surrounding disability are not compromised. This can lead to a better understanding for employees not only from a business prospective but also a social prospective with regard to people with disabilities

5. Findings

Arising from the interviews (*Ref: Appendices No. 8 – 19*) the following are the findings:

- All the Interviewees were positive about the culture in the company and a number of the Interviewees felt that the company would accommodate them if they were to have a disability whilst working for the company. Abbott has been named as one of the top 50 Companies to work for in Ireland and this was evident from the positive feedback that was given by the Interviewees in relation to the company.

- Disability is a sensitive subject and employees would require training to raise awareness in relation to disability as none of the Interviewees has experience working with a person with a disability in the company.

- All Interviewees were positive about working with a person with a disability however, initially a number of Interviewees were concerned and felt that a person with a disability would be unable to perform certain roles in the company. Following discussions in relation to disability the Interviewees began to look at their current positions and suggest adjustments that could be made to accommodate a person with a certain disability.

One of the Interviewees was a member of the Senior Management Team and it was interesting to note that the subject of disability had not been discussed at meetings. The impression given was that this was not a negative attitude towards disability, it was just that the subject was not discussed. This demonstrates that educating of employees in relation to disability should commence at Senior Management level in the company.

A question was raised by interviewee six was in relation to the facility and the current accommodations for people with disability i.e. disabled parking, disabled toilets and lift. The interviewee was unsure if this was the company just meeting the legal requirements. As outlined in *Section 1.4* earlier, this is an example of the company meeting its legal requirements for people with disabilities (*Ref: Appendix No. 20 Building Regulations*)

5. Recommendations

The recommendations arising from the Interviews (*Ref: Appendices No. 8 – 19*) conducted are very positive and the recommendations arising from these interviews would be as follows:

- a) Develop a Cross Functional Team which consist of a member of the HR Team, Environmental Health and Safety Team, Occupational Health Advisor, Training Department and a Department Manager to develop a Project Plan for Senior Managers on the best way to raise awareness amongst employees in relation to disability

- c) The Project Team to meet with the National Disability Authority (NDA) in relation to a Professional Body who could audit the facility to determine what the company needs to do to make the company more accessible for people with disabilities and the cost implications.
- d) The Project Team to deliver their findings to the Senior Management Team identifying a position in the company that the company would pilot recruiting and selecting a person with a disability. Also to get sign-off in relation to changes on the template for Job Specifications
- e) Provide Disability Awareness Training initially for all Team Leaders / Managers and to train a member of the Training Team on the site to become the official trainer for the Disability Awareness Training and to build this training programme into Orientation following training of existing employees.
- f) It was recommended that risk assessments be completed (from both a business risk assessment and individual risk assessment) on each position to determine if minor adjustments can be made to the role to accommodate a person with a disability. This would ensure that the health and safety of the person with a disability, existing employees and the integrity of the product are not compromised.

1. Literature Review

There have been many changes in the area of employment legislation particularly with regard to disability, which could be arising from Ireland's membership to both the United Nations and the EU, who have implemented laws, which have taken precedent over laws contained in The Irish Constitution of 1937.

These changes within legislations include the Employment Equality Acts 1988 and 2004 and this Act prohibit discrimination in the workplace on nine grounds and they are Gender, Marital Status, Family Status, Sexual Orientation, Religious Belief, Age, Disability, Race and Membership of the Traveller Community.

The Equality Tribunal was set-up as an independent forum that hears and mediates complaints of alleged discrimination under equality legislation. The Equality Authority also provides information to the public on the equality legislation.

Significant numbers of people with disabilities remain outside the workforce despite a capacity to make a contribution with a desire and a demand for participation. According to the Equality Authority in its published report in 2004 called

"An inclusive workforce" in January 2004, *"It is important to recognise that – both in Ireland and elsewhere – future growth and prospects are heavily dependent on successfully mobilising, retraining and developing increasingly diverse sources of labour. Equally, future prospects of social inclusion and social justice are heavily dependent on successfully accommodating this diversity in the workplace and in the wider society"*.

There was also a survey completed by the CIPD in 2006 called *"Diversity in Business: How much progress have employers made? First Findings"*. This survey found that 68% of companies in the UK had a diversity policy to "meet legal requirements".

This Project was to analyse if Abbott was taking its responsibility towards people with disability seriously and also should the company be doing more. The data was compiled following interviews with six employees at the company (*Ref: Appendices No. 8 – 19*). The questions that the interviewees were asked were designed to determine the knowledge of the employees in relation to people with disability and also to find out what the company currently does in relation to people with disability and what more could the company do.

2. Interview Findings

Arising from these interviews (*Ref: Appendices No. 8 – 19*) the following was the findings:

1. All interviewees felt that the company had a positive culture and would not discriminate against people with disabilities. The surprising element in the feedback, which invokes the positive culture in the company, a number of the interviewees, felt that if they had a physical disability, the interviewees were confident that the company would support them in their current role.
2. There were six employees interviewed and out of the six interviewees, none of the interviewees had experience working with a person with a disability in Abbott however, one interviewee had a new employee joining their team with a Medical disability.
3. Initially, all interviewees were negative about the possibility of a person with a disability working in their area however, towards the end of the interview the interviewees were reviewing the tasks that they do in their role and advising of minor changes that could be made to their jobs and to reflect these changes on the Job Specifications.

4. A number of interviewees requested that risk assessments be completed in relation to certain roles in the company prior to making changes to the Job Specifications
5. One interviewee found when applying for a position in the company, through the company website, was not user friendly and didn't apply for a position with the company until the interviewee heard the advertisement in local radio. This feedback is good because if the company is having difficulties attracting able-bodied candidates, the company is even less likely to receive applications from people with a disability.
6. All the interviewees were aware of the sensitivity of the subject of disability and requested the company to provide more information in relation to people with disabilities to ensure that the respect of the person with a disability was maintained.
7. One interviewee was a Senior Manager at the company and advised the interviewer that the matter in relation to disability was not discussed at meetings that the interviewee attended and this is important because if the company wants to embrace diversity, it must start at the top of the organisation and get its support before introducing it at different levels of the organisation.
8. The Government should be less reactive and more proactive in relation to Diversity and particularly in the area of disability as the literature review demonstrates that changes to legislation arise due to laws being implemented in the UN and EU.
9. The Government can be proactive is by auditing companies on an ongoing basis to ensure that companies meet the legal requirements laid down by the legislation.

3. Recommendations to Abbott

According to Catherine Maguire in her article in the Equality News of Winter 2005 titled "Understanding Disability", *'Notwithstanding demographic concerns, it is increasingly recognized that in order to move towards a knowledge based competitive economy, it will be necessary to draw on a diversity of talents and perspectives and to improve the participation of a number of groups who have not traditionally participated fully in the workplace.'*

Arising from the interviews (Ref: Appendices No. 8 – 19) held with six employees to determine if ADDLF takes its responsibility seriously in relation to people with disabilities the following are the recommendations arising from these findings:

1. the company has a positive culture which was echoed by all interviewees, it is important for the company to provide more information to employees in relation to interacting with people with disabilities from an employment, customer and social perspective.
2. the company currently have an Abbott Ireland Diversity Statement and employees must be made aware of this statement.
3. the company is currently training Line Managers in relation to Diversity and the company should provide this training to all employees through the Orientation Programme as having reviewed the training, the detail is appropriate and will provide good information for employees.
4. the company should develop a Diversity Policy and one that does not just meet the 'legal requirement' as outlined in the CIPD UK Survey as mentioned in the Literature Review where 68% of organizations in the UK had this policy with the key driver for having the policy is that the organization 'meets it legal requirements'.
5. It was recommended that risk assessments be completed (from both a business risk assessment and individual risk assessment) on each position to determine if minor adjustments can be made to the role to accommodate a person with a

disability. This would ensure that the health and safety of the person with a disability, existing employees and the integrity of the product are not compromised.

Conclusions

Abbott has a positive culture, which invokes the reason why it was voted as one of the top 50 Companies to work for in Ireland. However, the company should continue to build on this positive culture by being more proactive in the area of disability. It has been identified that the company does meet its legal requirements in relation to legislation and with regard to the design of the building but there is a lot more the company can do.

The company should develop a strategy to increase awareness in relation to disability in the company. This strategy should include training programmes, a diversity policy, review of job specifications and promoting the company to attract people with disabilities to apply for positions with Abbott.

The most important element of this strategy is that Senior Management of the company supports it as without this support the strategy will not succeed.

Chapter 6 References and Bibliography

Introduction

2005, Oireachtas “*Disability Act – Number 14 of 2005*”, Section 2 “*Interpretation*”

1976, World Health Organisation, “*International Definition of Disability*”

Chapter 2

1941, The London Charter

<http://www.un.org/>

1937, “The Constitution - Article 15 – Consitution and Powers – Section 2”

<http://www.europa.eu>

1997, “*Consolidation Version of the Treaty- Article 13*”, Amsterdam Treaty

EU Framework Directive

2004, “*Equality Act*”

Kandola and Fullerton , 1998. Diversity in action; managing the mosaic. “*Institute of Personnel Management*” (2nd edn)

Catherine Maguire, Winter 2005. Understanding Disability. “*Equality News*”

www.workway.ie

Ursula Halligan. 21 October 2007. Qualified people with disabilities the shame is that so few get a chance”. *Sunday Tribune*”

Professor Kathy Monk. 2007. The Business Impact of Equality and Diversity – The International Evidence. Equality Authority & National Centre for Partnership & Performance

Chartered Institute of Personnel & Development . 2007. *Managing Diversity measuring success* (Reference 3638)

Chartered Institute of Personnel & Development. 2006 *"Diversity in Business; How much success have employers made? First Findings"* Survey

Employee Handbook 2008 *"Abbott Ireland Diagnostics Division Longford Employee Handbook"* Cashills Printing, Leitrim

Chapter 3

Easterby-Smith, M., Thorpe, R. and Lowe, A. 2002 *Management Research: An Introduction* (2nd Edn) London, Sage

Chapter 5

Equality Authority. 2004 *"An inclusive workforce"* Equality Authority 2004

Chapter 7 Appendices and Questionnaires

Appendix No. 1	Charter of the United Nations
Appendix No. 2	Draft No. 1 – Interview Questions
Appendix No. 3	Draft No. 2 – Interview Questions
Appendix No. 4	Draft No. 3 – Interview Questions
Appendix No. 5	Draft No. 4 – Interview Questions
Appendix No. 6	Draft No. 5 – Interview Questions
Appendix No. 7	Details of Interviewees

(Appendix No. 7 Note to Examiner: To Be Removed following marking of Dissertation)

Appendix No. 8	Handwritten Notes from Interview No 1
Appendix No. 9	Typed Notes from Interview No. 1
Appendix No. 10	Handwritten Notes from Interview No 2
Appendix No. 11	Typed Notes from Interview No. 2
Appendix No. 12	Handwritten Notes from Interview No 3
Appendix No. 13	Typed Notes from Interview No. 3
Appendix No. 14	Handwritten Notes from Interview No 4
Appendix No. 15	Typed Notes from Interview No. 4
Appendix No. 16	Handwritten Notes from Interview No 5
Appendix No. 17	Typed Notes from Interview No. 5
Appendix No. 18	Handwritten Notes from Interview No 6
Appendix No. 19	Typed Notes from Interview No. 6
Appendix No. 10	Building Regulations 2000, Technical Guidance Document M, Access for People with Disabilities issued by Department for the Environment, Heritage and Local Government.

PREAMBLE

WE THE PEOPLES OF THE UNITED NATIONS DETERMINED

- to save succeeding generations from the scourge of war, which twice in our lifetime has brought untold sorrow to mankind, and
- to reaffirm faith in fundamental human rights, in the dignity and worth of the human person, in the equal rights of men and women and of nations large and small, and
- to establish conditions under which justice and respect for the obligations arising from treaties and other sources of international law can be maintained, and
- to promote social progress and better standards of life in larger freedom,

AND FOR THESE ENDS

- to practice tolerance and live together in peace with one another as good neighbours, and
- to unite our strength to maintain international peace and security, and
- to ensure, by the acceptance of principles and the institution of methods, that armed force shall not be used, save in the common interest, and
- to employ international machinery for the promotion of the economic and social advancement of all peoples,

HAVE RESOLVED TO COMBINE OUR EFFORTS TO ACCOMPLISH THESE AIMS

Accordingly, our respective Governments, through representatives assembled in the city of San Francisco, who have exhibited their full powers found to be in good and due form, have agreed to the present Charter of the United Nations and do hereby establish an international organization to be known as the United Nations.

Charter of the United Nations - Preamble

[full screen version](#)

[Return to UN Home Page](#)

Appendix No. 2

Draft No. 1 – Interview Questions

Tell me about Equality and Diversity in ADD Longford

What has been your experience with disability in the company

How do you feel it works or does not work

What do you think we should do differently

Appendix No. 3

Draft No. 2 – Interview Questions

Title of Dissertation: An analysis of Diversity within a multinational company with particular emphasis on disability

Tell me about Equality and Diversity in ADD Longford

Disability can be defined under the following headings:

Are you familiar with the definitions for Disability?

What has been your experience working with people with disability in the company

Do you feel the company takes its responsibility seriously in relation to people with disability?

What do you think the company should do differently

Appendix No. 4

Draft No. 3 – Interview Questions

Title of Dissertation: An analysis of Diversity within a multinational company with particular emphasis on disability

Tell me about Equality and Diversity in ADD Longford

Disability can be defined under the following headings:

- | | | |
|----|-----------------------------|---|
| a) | Blind and Visual Impairment | (Albinism and Nyslagmus, Diabetic Retinopathy, Glaucoma RP) |
| b) | Dear and Hard of Hearing | (Acoustic Neuroma, Deafness, Menieres Disease, Tinnitus) |
| c) | Speech Difficulties | (Stammer) |
| d) | Learning Difficulties | (Dyslexia, Dyspraxia, Attention Deficit Hyperactivity Disorder, Aspergers Syndrome) |
| e) | Physical Disabilities | (Cerebral Palsy, Muscular Dystrophy, Spina Bifida, Motor Neurone Disease) |
| f) | Medical Difficulties | (Multiple Sclerosis, Cystic Fibrosis, Epilepsy, Asthma) |
| g) | Mental Health Difficulties | (Bipolar Disorder, Manic Depression, Schizophrenia, Obsessive Compulsive Disorder) |

Are you familiar with the definitions for Disability?

What has been your experience working with people with disability in the company

Do you feel the company takes its responsibility seriously in relation to people with disability? Can you give examples?

What do you think the company should do differently?

Appendix No. 5

Draft No. 4 – Interview Questions

Interviewer: Antoinette Kenny

Interview No.: _____

Date: _____

Title of Dissertation: An analysis of Equality and Diversity within a multinational company with particular emphasis on disability

Interview Questions

Tell me about Equality and Diversity in ADD Longford

Disability can be defined under the following headings:

- a) Blind and Visual Impairment (Albinism and Nyslagmus, Diabetic Retinopathy, Glaucoma RP)
- b) Deaf and Hard of Hearing (Acoustic Neuroma, Deafness, Menieres Disease, Tinnitus)
- c) Speech Difficulties (Stammer)
- d) Learning Difficulties (Dyslexia, Dyspraxia, Attention Deficit Hyperactivity Disorder, Aspergers Syndrome)
- e) Physical Disabilities (Cerebral Palsy, Muscular Dystrophy, Spina Bifida, Motor Neurone Disease)
- f) Medical Difficulties (Multiple Sclerosis, Cystic Fibrosis, Epilepsy, Asthma)
- g) Mental Health Difficulties (Bipolar Disorder, Manic Depression, Schizophrenia, Obsessive Compulsive Disorder)

Are you familiar with the definitions for Disability?

What has been your experience working with people with disability in the company

Do you feel the company takes its responsibility seriously in relation to people with disability? Can you give examples?

What do you think the company should do differently?

Appendix No. 6

Draft No. 5 – Interview Questions

Interviewer: **Antoinette Kenny**

Interview No.: _____

Date: _____

Title of Dissertation: An analysis of Equality and Diversity within a multinational company with particular emphasis on disability

Interview Questions

Tell me about Equality and Diversity in ADD Longford

Disability can be defined under the following headings:

- a) Blind and Visual Impairment (Albinism and Nyslagmus, Diabetic Retinopathy, Glaucoma RP)
- b) Deaf and Hard of Hearing (Acoustic Neuroma, Deafness, Menieres Disease, Tinnitus)
- c) Speech Difficulties (Stammer)
- d) Learning Difficulties (Dyslexia, Dyspraxia, Attention Deficit Hyperactivity Disorder, Aspergers Syndrome)
- e) Physical Disabilities (Cerebral Palsy, Muscular Dystrophy, Spina Bifida, Motor Neurone Disease)
- f) Medical Difficulties (Multiple Sclerosis, Cystic Fibrosis, Epilepsy, Asthma)
- g) Mental Health Difficulties (Bipolar Disorder, Manic Depression, Schizophrenia, Obsessive Compulsive Disorder)

Are you familiar with the definitions for Disability?

What has been your experience working with people with disability in the company

Do you feel the company takes its responsibility seriously in relation to people with disability? Can you give examples?

What do you think the company should do differently?

Appendix No. 7

Details of Interviewees

Note from Author: The detail with regard to the interviewees is confidential and this document is for Examiners use only. Please remove from Dissertation, when it is corrected.

Interviewee No 1.	<u>margaret.goff@abbott.com</u>
Interviewee No. 2	<u>alan.hayes@abbott.com</u>
Interviewee No. 3	<u>aileen.ryan@abbott.com</u>
Interviewee No. 4	<u>ronan.cooney@abbott.com</u>
Interviewee No. 5	<u>sean.s.Kelly@abbott.com</u>
Interviewee No. 6	<u>martin.duffy@abbott.com</u>

Interviewer: Antoinette Kenny

Interview No.: 1

Date: 18 - Jun 08

Title of Dissertation: An analysis of Equality and Diversity within a multinational company with particular emphasis on disability

Interview Questions

Tell me about Equality and Diversity in ADD Longford

- Diversity - no of people of different nationalities working in Full / Label / outpack - French & Polish
 Equality - is get to know new employees, talk about similarities with each culture and also how talk about differences in culture - there is no language barrier so there is no communication problems - relate

Disability can be defined under the following headings:

- | | | |
|----|-----------------------------|---|
| a) | Blind and Visual Impairment | (Albinism and Nyctalopia, Diabetic Retinopathy, Glaucoma RP) |
| b) | Deaf and Hard of Hearing | (Acoustic Neuroma, Deafness, Menieres Disease, Tinnitus) |
| c) | Speech Difficulties | (Stammer) |
| d) | Learning Difficulties | (Dyslexia, Dyspraxia, Attention Deficit Hyperactivity Disorder, Aspergers Syndrome) |
| e) | Physical Disabilities | (Cerebral Palsy, Muscular Dystrophy, Spina Bifida, Motor Neurone Disease) |
| f) | Medical Difficulties | (Multiple Sclerosis, Cystic Fibrosis, Epilepsy, Asthma) |
| g) | Mental Health Difficulties | (Bipolar Disorder, Manic Depression, Schizophrenia, Obsessive Compulsive Disorder) |

Are you familiar with the definitions for Disability?

Heard of the different definitions but may not know "off the top of my head"

What has been your experience working with people with disability in the company

No experience to date but ~~or~~ has experience working in other companies

Do you feel the company takes its responsibility seriously in relation to people with disability? Can you give examples?

- No experience
- Knowledge of company would believe Abbott takes its responsibility seriously

What do you think the company should do differently?

- 1) WHEN APPLICANTS for a position with Abbott, found the website not very user friendly and felt under-qualified for role and applied following advertisement on local radio
The company should review how it advertises its positions on the website to ensure a wider pool of candidates are attracted to the company
- 2) On reflection, the interviewee outlined the different tasks in the area they work in and felt that the position would be suitable, with minor adjustments, to attract candidates that would be deflected under a number of the definitions overlaid

Appendix No. 9

Interview No. 1

Interviewer: Antoinette Kenny

Interview No.: 1

Date: 18 June 2008

Title of Dissertation: An analysis of Equality and Diversity within a multinational company with particular emphasis on disability

Interview Questions

Tell me about Equality and Diversity in ADD Longford

Diversity – there are a number of people of different nationalities working in Fill / Label / Kitpack – French and Polish

Equality – as you get to know new employees, talk about similarities with each culture and also talk about differences

Culture – there is no language barrier so there are no communication problems. When a group of people work together there is a tendency for these people to speak their own language, which can be awkward

Disability can be defined under the following headings:

- a) Blind and Visual Impairment (Albinism and Nyslagmus, Diabetic Retinopathy, Glaucoma RP)
- b) Deaf and Hard of Hearing (Acoustic Neuroma, Deafness, Menieres Disease, Tinnitus)
- c) Speech Difficulties (Stammer)
- d) Learning Difficulties (Dyslexia, Dyspraxia, Attention Deficit Hyperactivity Disorder, Aspergers Syndrome)
- e) Physical Disabilities (Cerebral Palsy, Muscular Dystrophy, Spina Bifida, Motor Neurone Disease)
- f) Medical Difficulties (Multiple Sclerosis, Cystic Fibrosis, Epilepsy, Asthma)
- g) Mental Health Difficulties (Bipolar Disorder, Manic Depression, Schizophrenia, Obsessive Compulsive Disorder)

Are you familiar with the definitions for Disability?

Heard of the different definitions but may not know "off the top of my head"

What has been your experience working with people with disability in the company

No experience to date but has experience working in other companies.

Do you feel the company takes its responsibility seriously in relation to people with disability? Can you give examples?

No experience

From knowledge of the company, would believe Abbott takes its responsibility seriously

What do you think the company should do differently?

1. When applying for a position with Abbott, found the website not very user friendly and felt under qualified for role and applied following advertisement in local radio

The company should review how it advertises its positions on the website to ensure a wider pool of candidates are attracted to the company

2. On reflection, the interviewee outlined the different tasks in the area they working in and felt that the position would be suitable, with minor adjustments, to attract candidates that would be defined under a number of the definitions overleaf.

Interviewer: Antoinette Kenny

Interview No.: 2

Date: 18 Jun 08

Title of Dissertation: An analysis of Equality and Diversity within a multinational company with particular emphasis on disability

Interview Questions

Tell me about Equality and Diversity in ADD Longford

Company is open to candidates from different countries and nationality nationalities. Aware of the fine grounds which a company should ensure they do not discriminate against.

Disability can be defined under the following headings:

- | | | |
|----|-----------------------------|---|
| a) | Blind and Visual Impairment | (Albinism and Nyslagmus, Diabetic Retinopathy, Glaucoma RP) |
| b) | Deaf and Hard of Hearing | (Acoustic Neuroma, Deafness, Menieres Disease, Tinnitus) |
| c) | Speech Difficulties | (Stammer) |
| d) | Learning Difficulties | (Dyslexia, Dyspraxia, Attention Deficit Hyperactivity Disorder, Aspergers Syndrome) |
| e) | Physical Disabilities | (Cerebral Palsy, Muscular Dystrophy, Spina Bifida, Motor Neurone Disease) |
| f) | Medical Difficulties | (Multiple Sclerosis, Cystic Fibrosis, Epilepsy, Asthma) |
| g) | Mental Health Difficulties | (Bipolar Disorder, Manic Depression, Schizophrenia, Obsessive Compulsive Disorder) |

Are you familiar with the definitions for Disability?

to a certain extent - some experience

What has been your experience working with people with disability in the company

As not aware of but some experience working with other companies

Do you feel the company takes its responsibility seriously in relation to people with disability? Can you give examples?

Yes - since the company would take its responsibility seriously - would accommodate if had personal disability while employed with Abbott

What do you think the company should do differently?

- Before attracting people with disability it would be best to assess the facilities and also to review the job specs

Would recommend a section of the job specification to detail what ^{is} involved - doing job x eg. involve 70% job work and 30% desk work, etc. - breakdown - by each job title

- Review by Professional Organisations to ensure accommodation of potential employees with disability
- ADD handout

Appendix No. 11

Interview No. 2

Interviewer: Antoinette Kenny

Interview No.: 2

Date: 18 June 2008

Title of Dissertation: An analysis of Equality and Diversity within a multinational company with particular emphasis on disability

Interview Questions

Tell me about Equality and Diversity in ADD Longford

The company is open to candidates from different countries and nationalities. Aware of the nine grounds which a company should ensure they do not discriminate against

Disability can be defined under the following headings:

- | | | |
|----|-----------------------------|---|
| a) | Blind and Visual Impairment | (Albinism and Nyslagmus, Diabetic Retinopathy, Glaucoma RP) |
| b) | Deaf and Hard of Hearing | (Acoustic Neuroma, Deafness, Menieres Disease, Tinnitus) |
| c) | Speech Difficulties | (Stammer) |
| d) | Learning Difficulties | (Dyslexia, Dyspraxia, Attention Deficit Hyperactivity Disorder, Aspergers Syndrome) |
| e) | Physical Disabilities | (Cerebral Palsy, Muscular Dystrophy, Spina Bifida, Motor Neurone Disease) |
| f) | Medical Difficulties | (Multiple Sclerosis, Cystic Fibrosis, Epilepsy, Asthma) |
| g) | Mental Health Difficulties | (Bipolar Disorder, Manic Depression, Schizophrenia, Obsessive Compulsive Disorder) |

Are you familiar with the definitions for Disability?

To some extent – some experience

What has been your experience working with people with disability in the company

No not aware of but some experience working with other companies

Do you feel the company takes its responsibility seriously in relation to people with disability? Can you give examples?

Yes, sure the company would take its responsibility seriously – would accommodate if had personal injury while employed in Abbott

What do you think the company should do differently?

1. Before attracting people with disabilities it would be best to assess the facilities and also to review Job Specifications
2. Would recommend a section on the Job Specifications to detail what is involved in doing the job e.g. involves 70% lab work and 30% desk work, etc. –breakdown by Job Title.
3. Review by Professional Organisations to ensure accommodation of potential employees with disability in Abbott Longford

Interviewer: **Antoinette Kenny**

Interview No.: 3

Date: 14 June 08

Title of Dissertation: An analysis of Equality and Diversity within a multinational company with particular emphasis on disability

Interview Questions

Tell me about Equality and Diversity in ADD Longford

*equal division of male / female employees and also in relation to married / single employees
 full full people are promoted - the company based on skills and ability to do job
 regardless of the same gender and discrimination - about*

Disability can be defined under the following headings:

- a) Blind and Visual Impairment (Albinism and Nyslagmus, Diabetic Retinopathy, Glaucoma RP)
- b) Deaf and Hard of Hearing (Acoustic Neuroma, Deafness, Menieres Disease, Tinnitus)
- c) Speech Difficulties (Stammer)
- d) Learning Difficulties (Dyslexia, Dyspraxia, Attention Deficit Hyperactivity Disorder, Aspergers Syndrome)
- e) Physical Disabilities (Cerebral Palsy, Muscular Dystrophy, Spina Bifida, Motor Neurone Disease)
- f) Medical Difficulties (Multiple Sclerosis, Cystic Fibrosis, Epilepsy, Asthma)
- g) Mental Health Difficulties (Bipolar Disorder, Manic Depression, Schizophrenia, Obsessive Compulsive Disorder)

*is an equal opportunity etc
 let more foreign employees since
 employee started in 2004*

Are you familiar with the definitions for Disability?

*Would be familiar with most of definitions
 when disability is noticed one automatically assumes its a person - a wheelchair*

What has been your experience working with people with disability in the company

*Medical / Mental Health Difficulties are confidential information and is unaware of people with this disability
 in relation to the other definitions of disability has no exp - ADDLE wkg with a person with one of these disabilities*

Do you feel the company takes its responsibility seriously in relation to people with disability? Can you give examples?

Assembly have disabled parking, lift and disabled toilets - because of Abbott have policies - relate to disability.

What do you think the company should do differently?

- Educate employees - relate to disability
- Review advertising of jobs
- Review each job - be with industry regulations to do with regard to the seven definitions of disability.

Appendix No. 13

Interview No. 3

Interviewer: Antoinette Kenny

Interview No.: 3

Date: 19 June 2008

Title of Dissertation: An analysis of Equality and Diversity within a multinational company with particular emphasis on disability

Interview Questions

Tell me about Equality and Diversity in ADD Longford

There is an equal division of male/female employees and also in relation to married/single employees. Feel people are promoted in the company based on skill and ability to do the job. Abbott is an equal opportunity employer since interviewee started with company in 2004

Disability can be defined under the following headings:

- | | | |
|----|-----------------------------|---|
| a) | Blind and Visual Impairment | (Albinism and Nyslagmus, Diabetic Retinopathy, Glaucoma RP) |
| b) | Deaf and Hard of Hearing | (Acoustic Neuroma, Deafness, Menieres Disease, Tinnitus) |
| c) | Speech Difficulties | (Stammer) |
| d) | Learning Difficulties | (Dyslexia, Dyspraxia, Attention Deficit Hyperactivity Disorder, Aspergers Syndrome) |
| e) | Physical Disabilities | (Cerebral Palsy, Muscular Dystrophy, Spina Bifida, Motor Neurone Disease) |
| f) | Medical Difficulties | (Multiple Sclerosis, Cystic Fibrosis, Epilepsy, Asthma) |
| g) | Mental Health Difficulties | (Bipolar Disorder, Manic Depression, Schizophrenia, Obsessive Compulsive Disorder) |

Are you familiar with the definitions for Disability?

Would be familiar with most of the definitions. When disability is mentioned, one automatically assumes it is a person in a wheelchair

What has been your experience working with people with disability in the company

Medical / Mental Health Difficulties are confidential information and is unaware of people with this disability

In relation to the other definitions on disability, have no experience in Abbott Longford working with a person with one of these disabilities

Do you feel the company takes its responsibility seriously in relation to people with disability? Can you give examples?

Currently have disabled parking, lift and disabled toilets – Unsure if Abbott have policies in relation to disability

What do you think the company should do differently?

1. Educate employees in relation to disability
2. Review advertising of jobs
3. Review each job in line with industry regulations with regard to the seven definitions of disability

Interviewer: Antoinette Kenny

Interview No.: 4

Date: 19 Jun 08

Title of Dissertation: An analysis of Equality and Diversity within a multinational company with particular emphasis on disability

Interview Questions

Tell me about Equality and Diversity in ADD Longford

*good = relation to equality & diversity
wide range of diversity = ADDLF
people are promoted based on skill
wouldn't feel ADDLF would discriminate = relation
to race. - Abbott is very fair*

Disability can be defined under the following headings:

- | | | |
|----|-----------------------------|---|
| a) | Blind and Visual Impairment | (Albinism and Nyslagmus, Diabetic Retinopathy, Glaucoma RP) |
| b) | Deaf and Hard of Hearing | (Acoustic Neuroma, Deafness, Menieres Disease, Tinnitus) |
| c) | Speech Difficulties | (Stammer) |
| d) | Learning Difficulties | (Dyslexia, Dyspraxia, Attention Deficit Hyperactivity Disorder, Aspergers Syndrome) |
| e) | Physical Disabilities | (Cerebral Palsy, Muscular Dystrophy, Spina Bifida, Motor Neurone Disease) |
| f) | Medical Difficulties | (Multiple Sclerosis, Cystic Fibrosis, Epilepsy, Asthma) |
| g) | Mental Health Difficulties | (Bipolar Disorder, Manic Depression, Schizophrenia, Obsessive Compulsive Disorder) |

Are you familiar with the definitions for Disability?

*No - not really thought about it but it makes sense
tendency to stereotyped to physical disability*

What has been your experience working with people with disability in the company

No experience = ADD Longford.

Do you feel the company takes its responsibility seriously in relation to people with disability? Can you give examples?

- Disabled parking, lift - building is wheelchair accessible, Disabled toilets
- I've worked with a person with disability ~~at~~ ^{at} work - able to assess - felt confident of company ^{support} = the extent of an accident leading to personal disability
- What do you think the company should do differently? per 12 employees
- getting them done would be considered.
- ~~physical~~ physical modifications will have capital expenditure and analysis would need to be carried out
- Review the jobs ^{with disabilities} with specific requirements with attracts a pool of candidates for positions = ADD covered
- handle very sensitively

Appendix No. 15

Interview No. 4

Interviewer: Antoinette Kenny

Interview No.: 4

Date: 19 June 2008

Title of Dissertation: An analysis of Equality and Diversity within a multinational company with particular emphasis on disability

Interview Questions

Tell me about Equality and Diversity in ADD Longford

Good in relation to Equality and Diversity

Wide range of diversity in Abbott Longford

People are promoted based on skill

Wouldn't feel Abbott Longford would discriminate in relation to race or gender – Abbott is very fair

Disability can be defined under the following headings:

- | | | |
|----|-----------------------------|---|
| a) | Blind and Visual Impairment | (Albinism and Nyslagmus, Diabetic Retinopathy, Glaucoma RP) |
| b) | Deaf and Hard of Hearing | (Acoustic Neuroma, Deafness, Menieres Disease; Tinnitus) |
| c) | Speech Difficulties | (Stammer) |
| d) | Learning Difficulties | (Dyslexia, Dyspraxia, Attention Deficit Hyperactivity Disorder, Aspergers Syndrome) |
| e) | Physical Disabilities | (Cerebral Palsy, Muscular Dystrophy, Spina Bifida, Motor Neurone Disease) |
| f) | Medical Difficulties | (Multiple Sclerosis, Cystic Fibrosis, Epilepsy, Asthma) |
| g) | Mental Health Difficulties | (Bipolar Disorder, Manic Depression, Schizophrenia, Obsessive Compulsive Disorder) |

Are you familiar with the definitions for Disability?

No, not really thought about it but it makes sense

Tendency to stereotype to physical disability

What has been your experience working with people with disability in the company

No experience working in Abbott Longford

Do you feel the company takes its responsibility seriously in relation to people with disability? Can you give examples?

Disabled Parking, Lift – Building is wheelchair accessible, Disabled Toilets
Until work with a person with disability, I am unable to assess – feel confident of company support in the event of an accident leading to a disability

What do you think the company should do differently?

1. Getting through the doors would be awkward
2. Physical modifications will have capital expenditure and analysis would need to be carried out
3. Review the jobs in line with attracting a pool of candidates with disabilities with disabilities for positions in Abbott Longford
4. Handle very sensitively

Interviewer: Antoinette Kenny

Interview No.: 5

Date: 19 Jun 08

Title of Dissertation: An analysis of Equality and Diversity within a multinational company with particular emphasis on disability

Interview Questions

Tell me about Equality and Diversity in ADD Longford

*Yes - equal opportunity employed - don't ask discriminatory
 Qs - encouraged not to ask discriminatory Qs - university
 costs alot of money and bars of headcount - never look at
 that when doing interviews - 50:50 male/female divide
 never interviewed a person with disability - in case from HRIS
 Disability can be defined under the following headings: ~~some~~ some disabilities will
be precluded*

- a) Blind and Visual Impairment (Albinism and Nyslagmus, Diabetic Retinopathy, Glaucoma RP)
- b) Deaf and Hard of Hearing (Acoustic Neuroma, Deafness, Menieres Disease, Tininitis)
- c) Speech Difficulties (Stammer)
- d) Learning Difficulties (Dyslexia, Dyspraxia, Attention Deficit Hyperactivity Disorder, Aspergers Syndrome)
- e) Physical Disabilities (Cerebral Palsy, Muscular Dystrophy, Spina Bifida, Motor Neurone Disease)
- f) Medical Difficulties (Multiple Sclerosis, Cystic Fibrosis, Epilepsy, Asthma)
- g) Mental Health Difficulties (Bipolar Disorder, Manic Depression, Schizophrenia, Obsessive Compulsive Disorder)

Are you familiar with the definitions for Disability?

*not familiar with specific - but would
 have known some of the definitions*

What has been your experience working with people with disability in the company

No

Do you feel the company takes its responsibility seriously in relation to people with disability? Can you give examples?

Disability toilets, lift, parking
don't know any employees with disability

What do you think the company should do differently?

- look at categories and do assessment against job specs
- Risk assessment

Appendix No. 17

Interview No. 5

Interviewer: Antoinette Kenny

Interview No.: 5

Date: 19 June 2008

Title of Dissertation: An analysis of Equality and Diversity within a multinational company with particular emphasis on disability

Interview Questions

Tell me about Equality and Diversity in ADD Longford

Yes – equal opportunity employer – don't ask discriminatory questions and encouraged not to ask discriminatory questions. Maternity costs a lot of money and loss of headcount the company never looks at it when doing interviews. 50:50 male/female divide. Never interviewed a person with disability, in the area of Health & Safety, some disabilities will be precluded

Disability can be defined under the following headings:

- | | | |
|----|-----------------------------|---|
| a) | Blind and Visual Impairment | (Albinism and Nyslagmus, Diabetic Retinopathy, Glaucoma RP) |
| b) | Deaf and Hard of Hearing | (Acoustic Neuroma, Deafness, Menieres Disease, Tinnitus) |
| c) | Speech Difficulties | (Stammer) |
| d) | Learning Difficulties | (Dyslexia, Dyspraxia, Attention Deficit Hyperactivity Disorder, Aspergers Syndrome) |
| e) | Physical Disabilities | (Cerebral Palsy, Muscular Dystrophy, Spina Bifida, Motor Neurone Disease) |
| f) | Medical Difficulties | (Multiple Sclerosis, Cystic Fibrosis, Epilepsy, Asthma) |
| g) | Mental Health Difficulties | (Bipolar Disorder, Manic Depression, Schizophrenia, Obsessive Compulsive Disorder) |

Are you familiar with the definitions for Disability?

Not familiar with specific – but would have know some of the definitions

What has been your experience working with people with disability in the company

No

Do you feel the company takes its responsibility seriously in relation to people with disability? Can you give examples?

Disabled Toilets, Lift, Park

Don't know any employee with a disability

What do you think the company should do differently?

1. Look at categories and do assessment against Job Specifications
2. Risk Assessment

Interviewer: Antoinette Kenny

Interview No.: 6

Date: 20 Jun 08

Title of Dissertation: An analysis of Equality and Diversity within a multinational company with particular emphasis on disability

Interview Questions

Tell me about Equality and Diversity in ADD Longford

*good = relative
recruited Polish & Nigerian
from the part of view, race is never an issue
have a number = Dept from different countries
never come up*

Disability can be defined under the following headings:

- | | | |
|----|-----------------------------|---|
| a) | Blind and Visual Impairment | (Albinism and Nyslagmus, Diabetic Retinopathy, Glaucoma RP) |
| b) | Deaf and Hard of Hearing | (Acoustic Neuroma, Deafness, Menieres Disease, Tinnitus) |
| c) | Speech Difficulties | (Stammer) |
| d) | Learning Difficulties | (Dyslexia, Dyspraxia, Attention Deficit Hyperactivity Disorder, Aspergers Syndrome) |
| e) | Physical Disabilities | (Cerebral Palsy, Muscular Dystrophy, Spina Bifida, Motor Neurone Disease) |
| f) | Medical Difficulties | (Multiple Sclerosis, Cystic Fibrosis, Epilepsy, Asthma) |
| g) | Mental Health Difficulties | (Bipolar Disorder, Manic Depression, Schizophrenia, Obsessive Compulsive Disorder) |

Are you familiar with the definitions for Disability?

*to a certain extent
may not know all seven*

What has been your experience working with people with disability in the company

*No experience
Have a new employee starts with medical difficulties*

Do you feel the company takes its responsibility seriously in relation to people with disability? Can you give examples?

Not 100% sure of guidelines
never came up in meetings

if we knew them and knowing the culture it would
be taking seriously - 100% right attitude - company

What do you think the company should do differently?

system - place - company to make people aware
of standards guidelines
- legal obligations

Appendix No. 19

Interview No. 6

Interviewer: Antoinette Kenny

Interview No.: 6

Date: 20 June 2008

Title of Dissertation: An analysis of Equality and Diversity within a multinational company with particular emphasis on disability

Interview Questions

Tell me about Equality and Diversity in ADD Longford

Good in relation to Equality and Diversity

Recruited Polish and Nigerian nationalities

From interview point of view, race is never an issue and have a number in Department from different countries

Never came up in meetings

Disability can be defined under the following headings:

- | | | |
|----|-----------------------------|---|
| a) | Blind and Visual Impairment | (Albinism and Nyslagmus, Diabetic Retinopathy, Glaucoma RP) |
| b) | Deaf and Hard of Hearing | (Acoustic Neuroma, Deafness, Menières Disease, Tinnitus) |
| c) | Speech Difficulties | (Stammer) |
| d) | Learning Difficulties | (Dyslexia, Dyspraxia, Attention Deficit Hyperactivity Disorder, Aspergers Syndrome) |
| e) | Physical Disabilities | (Cerebral Palsy, Muscular Dystrophy, Spina Bifida, Motor Neurone Disease) |
| f) | Medical Difficulties | (Multiple Sclerosis, Cystic Fibrosis, Epilepsy, Asthma) |
| g) | Mental Health Difficulties | (Bipolar Disorder, Manic Depression, Schizophrenia, Obsessive Compulsive Disorder) |

Are you familiar with the definitions for Disability?

To a certain extent, my not know all seven

What has been your experience working with people with disability in the company

No – Have a new employee starting with medical difficulties

Do you feel the company takes its responsibility seriously in relation to people with disability? Can you give examples?

Not 100% sure of guidelines, never came up in meetings

If we knew them and knowing the culture it would be taken seriously – 100% right culture in company

Legal obligations in relation to disabled toilets, disable parking and lift

What do you think the company should do differently?

1. Implement a system in the company to make people aware or provide guidelines

Building Regulations 2000

Technical Guidance Document M

Access for People with Disabilities

BAILE ÁTHA CLIATH:

ARNA FHOILSIÚ AG OIFIG AN tSOLÁTHAIR

Le ceannach díreach ón

OIFIG DHÍOLTA FOILSEACHÁIN RIALTAIS,

TEACH SUN ALLIANCE, SRÁID THEACH LAIGHEAN, BAILE ÁTHA CLIATH 2,

nó tríd an bpost ó

FOILSEACHÁIN RIALTAIS, AN RANNÓG POST-TRÁCHTA,

51 FAICHE STABHNA, BAILE ÁTHA CLIATH 2,

(Teil: 01-6476000, Fax: 01-647 6843)

nó trí aon díoltóir leabhar.

DUBLIN

PUBLISHED BY THE STATIONERY OFFICE

To be purchased from the

GOVERNMENT PUBLICATIONS SALE OFFICE,

SUN ALLIANCE HOUSE, MOLESWORTH STREET, DUBLIN 2.

or by mail order from

GOVERNMENT PUBLICATIONS, POSTAL TRADE SECTION,

51 ST. STEPHENS GREEN, DUBLIN 2,

(Tel: 01-6476000; Fax: 01-647 6843)

or through any bookseller.

Price: €3.81



Printed on recycled paper
containing a minimum of
75% post-consumer waste



Amendments issued since publication

Technical Guidance Document M - Access for People with Disabilities

Amd. No.	Text Affected
M(i)	Paragraph 1.4 (f) should read: “where the gradient is steeper than 1 in 20, there should be a suitable continuous handrail on each side of slopes and landings (see par. 1.6)”.
M(ii)	Paragraph 1.30 (e): “280 mm” should read “250 mm”.
M(iii)	Paragraph 2.9: Replace final sentence with following: “The choice of door type and location should be such as not to pose undue hazard on a circulation route or be otherwise dangerous in use”.

	Page
Introduction	2
Transitional Arrangements	2
The Guidance	2
Existing Buildings	2
Technical Specifications	2
Materials and Workmanship	2
Interpretation	2
Part M : The Requirement	3
General	3
ACCESS AND USE	
Section 1a: Buildings other than dwellings	5
Approach to a building	5
Access into a building	8
Circulation within a building	9
Use of facilities in a building	11
Hotel and other guest bedrooms	13
Section 1b: Dwellings	15
Approach to a dwelling	15
Access into a dwelling	16
Circulation within a dwelling	16
Section 2 SANITARY CONVENIENCES	18
Section 2a: Buildings other than dwellings	18
Section 2b: Dwellings	22
Section 3	
AUDIENCE OR SPECTATOR FACILITIES	25
STANDARDS AND OTHER REFERENCES	26

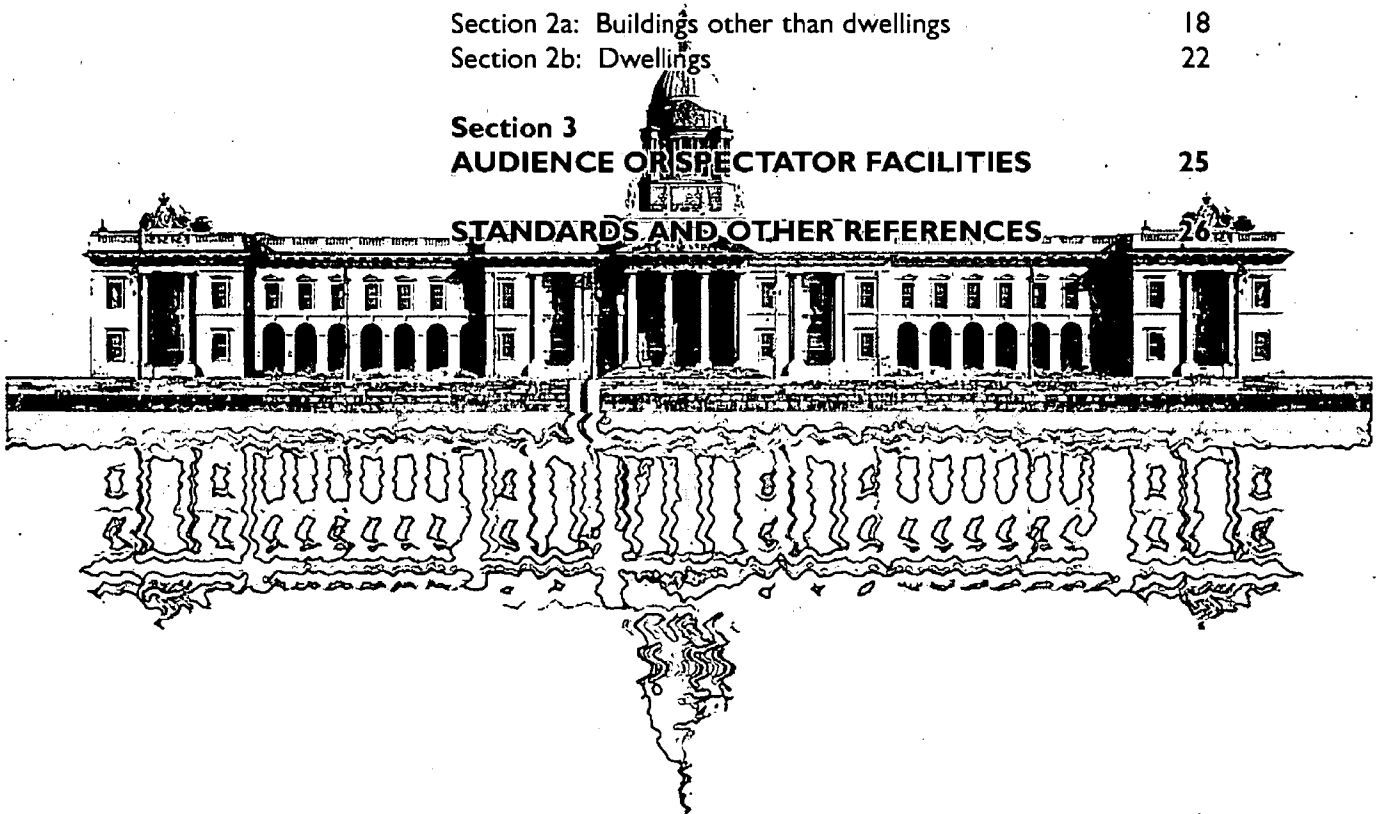

Technical Guidance Document M

Access for People with Disabilities

Introduction

This document has been published by the Minister for the Environment under article 7 of the Building Regulations. It provides guidance in relation to the revised Part M of the Second Schedule to the Regulations. The document should be read in conjunction with the Building Regulations, 1997, and 2000 and other documents published under these Regulations.

In general, Building Regulations apply to the construction of new buildings and to extensions and material alterations to buildings. In addition, certain parts of the Regulations apply to existing buildings where a material change of use takes place. Otherwise, Building Regulations do not apply to buildings constructed prior to 1 June, 1992.

Transitional Arrangements

In general, this document applies to works, where the works commence, on or after 1 January, 2001 except in the case of new dwellings where planning permission has been applied for on or before 31 December, 2000 and where substantial works have been completed by 31 December, 2003, or a notice pursuant to Part X of the Local Government (Planning and Development) Regulations, 1994 has been published on or before 31 December, 2000 and where substantial works have been completed by 31 December, 2003. Technical Guidance Document M - **Access for Disabled People**, dated 1997, also ceases to have effect from that date. However, the latter document may continue to be used in the case of works, or buildings

- where the works commence, as the case may be, before 1 January, 2001,
- in respect of which a Fire Safety Certificate under the Building Control Regulations, has been granted before 1 January, 2001 and where the works commence, not later than 31 December, 2003.

The Guidance

The materials, methods of construction, standards and other specifications (including technical specifications) which are referred to in this document are those which are likely to be suitable for the purposes of the Regulations. Where works are carried out in accordance with the guidance in this document, this will, prima facie, indicate compliance with Part M of the Second Schedule to the Building Regulations (as amended). However, the adoption of an approach other than that outlined in the guidance is not precluded provided that the relevant requirements of the Regulations are complied with. Those involved in the design and construction of a building may be required by the relevant building control authority to provide such evidence as is necessary to establish that the requirements of the Building Regulations are being complied with.

Existing Buildings

In the case of material alterations of existing buildings, the adoption without modification of the guidance in this document may not, in all circumstances, be appropriate. In particular, the adherence to guidance, including codes, standards or technical specifications, intended for application to new work may be unduly restrictive or impracticable. Buildings of architectural or historical interest are especially likely to give rise to such circumstances. In these situations, alternative approaches based on the principles contained in the document may be more relevant and should be considered.

Technical Specifications

Building Regulations are made for specific purposes, e.g. to provide, in relation to buildings, for the health, safety and welfare of persons, the conservation of energy and access for disabled persons. Technical specifications (including harmonised European Standards, European Technical Approvals, National Standards and Agrément Certificates) are relevant to the extent that they relate to these considerations. Any reference to a technical specification is a reference to so much of the specification as is relevant in the context in which it arises. Technical specifications may also address other aspects not covered by the Regulations.

A reference to a technical specification is to the latest edition (including any amendments, supplements or addenda) current at the date of publication of this Technical Guidance Document. However, if this version of the technical specification is subsequently revised or updated by the issuing body, the new version may be used as a source of guidance provided that it continues to address the relevant requirements of the Regulations.

Materials and Workmanship

Under Part D of the Second Schedule to the Building Regulations, building work to which the Regulations apply must be carried out with proper materials and in a workmanlike manner. Guidance in relation to compliance with Part D is contained in Technical Guidance Document D.

Interpretation

In this document, a reference to a section, sub-section, part, paragraph or diagram is, unless otherwise stated, a reference to a section, sub-section, part, paragraph or diagram, as the case may be, of this document. A reference to another Technical Guidance Document is a reference to the latest edition of a document published by the Department of the Environment under article 7 of the Building Regulations (as amended). Diagrams are used in this document to illustrate particular aspects of construction - they may not show all the details of construction.

Building Regulations - The Requirement

Part M of the Second Schedule to the Building Regulations, (as amended), provides as follows :

Access and Use	M1	Adequate provision shall be made to enable people with disabilities to safely and independently access and use a building.
Sanitary conveniences	M2	If sanitary conveniences are provided in a building, adequate provision shall be made for people with disabilities.
Audience or Spectator facilities	M3	If a building contains fixed seating for audience or spectators, adequate provision shall be made for people with disabilities.
Definition for this Part	M4	In this Part, "people with disabilities" means people who have an impairment of hearing or sight or an impairment which limits their ability to walk or which restricts them to using a wheelchair.
Application of this Part	M5	Part M does not apply to works in connection with extensions to and the material alterations of existing dwellings, provided that such works do not create a new dwelling.

General

0.1 The requirements of Part M aim to ensure that :

- (a) buildings other than dwellings are accessible and usable by people with disabilities, and
- (b) dwellings are visitable by people with disabilities.

This document sets out guidance on the *minimum* level of provision to meet these requirements. However, the underlying philosophy on which these requirements are based is that buildings should be accessible and usable by everyone, including people with disabilities. Those involved in the design and construction of buildings should have regard to this philosophy of universal access, and should consider making additional provision where practicable and appropriate.

0.2 In order to satisfy the requirements of Part M, buildings should be designed and constructed so that:

- (a) people with disabilities can safely and independently approach and gain access to the building, and

- (b) elements of the building do not constitute an undue hazard for people with disabilities, including those with an impairment of sight.

0.3 In the case of buildings other than dwellings, the building should be designed and constructed so that:

- (a) people with disabilities can move around within the building and use the buildings facilities;
- (b) where sanitary accommodation is provided, adequate sanitary accommodation is available and accessible to people with disabilities;
- (c) where fixed seating for audience or spectators is provided, adequate accommodation is available for people with disabilities; and
- (d) suitable aids to communication are available for people with an impairment of hearing or sight.

0.4 Dwellings should be designed and constructed so that:

-
- (i) people with disabilities can safely and conveniently approach and gain access;

On some steeply sloping sites, or where all entrances are on other than ground level and a suitable passenger lift is not provided, it is considered adequate to provide access by means of steps or a stairway suitable for use by ambulant disabled people;

- (ii) people with disabilities can have access to the main habitable rooms at entry level. Where there is no habitable room at this level, it is considered adequate to provide for access to habitable rooms on the storey containing the main living room. Access to this storey from the entry storey may be by means of a stairway suitable for use by ambulant disabled people;
- (iii) a WC is provided at entry level or, where there are no habitable rooms at this level, on the storey containing the main living room with adequate provision for access and use of the WC by people with disabilities.

0.5 The requirements of Part M apply to works in connection with new buildings, extensions to existing buildings and material alterations of existing buildings. However, in the case of existing dwellings, the requirements only apply to works in connection with extensions and material alterations where such works create a new additional dwelling.

Where access to an extension or accommodation which is subject to a material alteration, to which this Part applies, is through an existing building, the access requirements in relation to the approach route to the extension or material alteration, including relevant existing entrances, will only apply to that part of the route which is being materially altered or to the extent required to prevent a new or greater contravention of the Regulations.

However, in the case of hotels, cinemas, educational establishments and similar places of assembly, if the existing entrance is not accessible to wheelchair users, an alternative entrance should be provided which is accessible to wheelchair users and which will enable them to gain independent access to an

extension to which it is intended that members of the public would normally have access.

0.6 Access provision must be linked to egress provision. The scope of Part M is limited to matters of access to and use of a building. For guidance on means of escape or evacuation, reference should be made to Technical Guidance Document B (Fire Safety).

0.7 Diagrams included in this Document are intended to clarify certain aspects of the guidance. They are not necessarily to scale and do not represent fully detailed solutions. Where dimensions are stated, they refer to *minimum* finished dimensions. Allowance should be made for all necessary tolerances and finishes. Reference should be made to Technical Guidance Document D (Materials and Workmanship) for guidance in relation to manufacturing and other tolerances applicable to building components generally.

Access and Use

Access and use

M1

Adequate provision shall be made to enable people with disabilities, to safely and independently access and use a building.

Section 1a Buildings other than dwellings

Approach to a Building

1.1 The guidance in Section 1a applies to buildings other than dwellings including, where applicable, to common areas of apartment blocks and the like.

1.2 To reduce the risks to people with disabilities, particularly those with impaired sight, building features which may present hazards on circulation routes immediately adjacent to them, should be avoided. For example, a window or a door in general use should not open out onto a circulation route. In general all approach routes should have clear headroom of 2.2 m over their full width. A lesser height may be accepted over a short distance, e.g. the underside of an adjacent stairs or landing, but should not be less than 2 m (see *Diagram 1*). Where such hazards are unavoidable the area should be protected by guarding, planting or other suitable barriers.

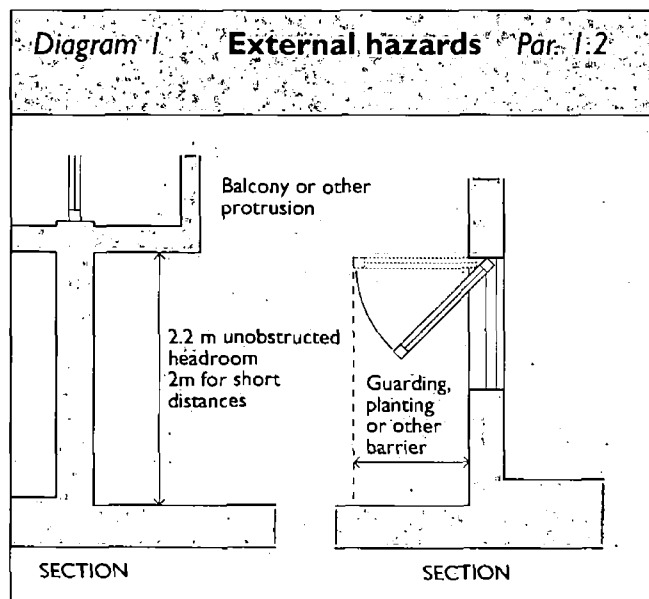

1.3 The main entrance or entrances should be accessible to people with disabilities, including wheelchair users. Where this is not practicable, an alternative entrance, intended for general access, should be accessible. There should be a clear area of at least 1.5 m wide and at least 1.5 m deep in front of every such entrance. The approach to the

entrance from the adjacent road, carpark or other area accessible to motor vehicles should be level. If a gradient is needed, e.g. to remove surface water, it should be as gentle as circumstances allow (a level approach is considered to include gradients of less than 1 : 50). The approach should have a clear unobstructed width of at least 1.0 m and should have a surface which is suitable for wheelchair traffic and which reduces the risk of slipping. Where it is not possible to provide a level approach, a sloped approach with as gentle a gradient as possible (see par. 1.4) should be provided. Where the slope is steeper than 1 : 20, a stepped approach should also be provided. The steps should be as easy-going as possible (see par. 1.5).

1.4 Where a sloped approach is provided :

- the surface should be suitable for wheelchair traffic and reduce the risk of slipping;
- slopes and landings should have a clear unobstructed width of at least 1.0 m;
- the gradient should not be steeper than 1 in 20 and individual sloped sections not longer than 9 m. In exceptional circumstances, where site constraints require it, slopes not steeper than 1 : 12 may be provided if individual sections are not longer than 4.5 m;
- the length of a landing viewed in the direction of approach to the landing should be at least 1.0 m. Where a door opens onto a landing, the length of the landing should be at least 1.3 m clear of the door swing. The top landing should be at least 1.5 m wide and 1.5 m long, to facilitate wheelchair turning;
- a raised kerb at least 75 mm high should be provided on any open side;
- where the gradient is steeper than 1 in 20, there should be a suitable continuous handrail on each side of slopes and landings (see par. 1.6).

Diagram 2 illustrates the guidance on sloped approaches.

Handrails on each side of flights and landings.
1 m min. between handrails

FLIGHT LENGTH:
• max 9m at slope of 1 in 20,
• max 4.5m at slope 1 in 12

Note: Stepped approach not required if slope flatter than 1 in 20, but top landing 1.5m x 1.5m min.

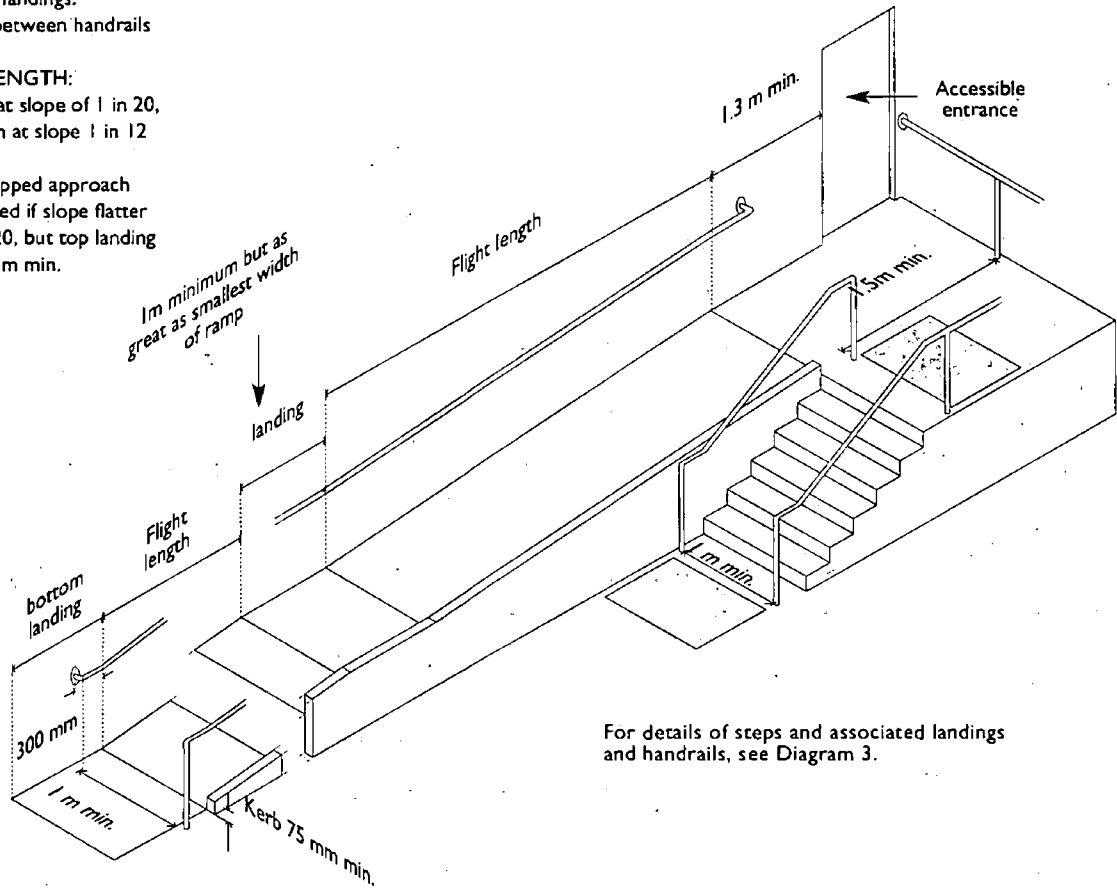

For details of steps and associated landings and handrails, see Diagram 3.

1.5 Where external steps are provided:

- (a) top and bottom landings with a tactile danger warning surface should be provided, to give advance tactile warning of the change in level. The tactile warning surface should extend the full width of the steps and commence 400 mm back from the first step. It should be 800 mm deep. The depth may be reduced to 400 mm where a head-on approach to the steps is not possible (see Diagram 3);
- (b) the first and last steps in each flight should provide a permanent visual contrast with the rest of the steps. The step edge markings on treads should be 50-75 mm deep and extend the full width of the tread;
- (c) flights and landings should have a clear unobstructed width of at least 1.0 m;
- (d) the rise of a flight between landings should not exceed 1.5 m;
- (e) the length of a landing clear of any obstruction or door swing should be at least 1 m when viewed in the direction of approach to the landing;
- (f) the rise of each step should be uniform and not more than 150 mm;
- (g) the going of each step should be uniform and not less than 280 mm;
- (h) the sum of twice the rise plus the going ($2R + G$) should be not greater than 630 mm;
- (i) tapered treads and open risers should not be used;
- (j) projecting nosings should be avoided - see tread/riser profiles shown in Diagram 3;

- (k) there should be a suitable continuous handrail on each side of flights and landings (see par. 1.6).

Diagrams 2 and 3 illustrate guidance on stepped approaches

1.6 Handrails suitable for sloped or stepped approaches should comply with the following:

- (a) the top of the handrail should be at a height of between 840 mm and 900 mm above the pitch line of the slope or the flight of steps and between 840 mm and 1000 mm above the surface of the landing;
- (b) the handrails should be continuous at intermediate landings;

- (c) where the handrail is not continuous the handrail should extend at least 300 mm beyond the top and bottom of a sloped approach or the top and bottom risers of a stepped approach, and terminate in a closed end which does not project into a route of travel;

- (d) the profile of the handrail and its projection from a wall should be suitable.

Diagram 4 contains guidance on handrail design. See Technical Guidance Document K (Stairways, Ladders, Ramps and Guards) for guidance on the provision of guarding.

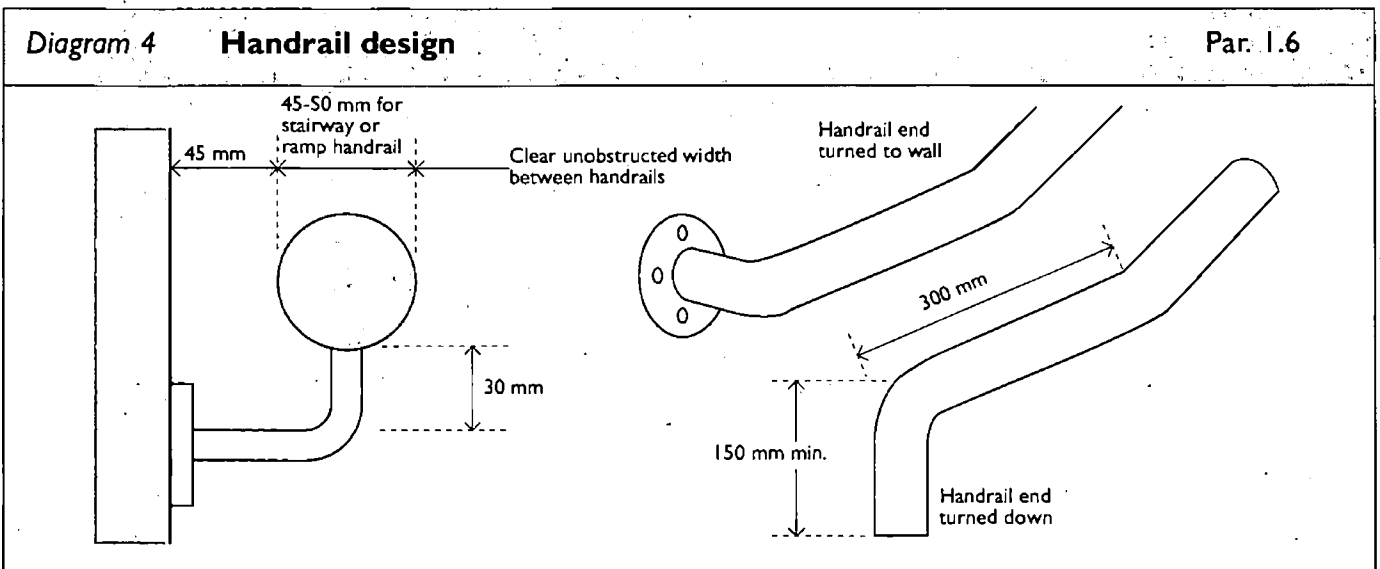
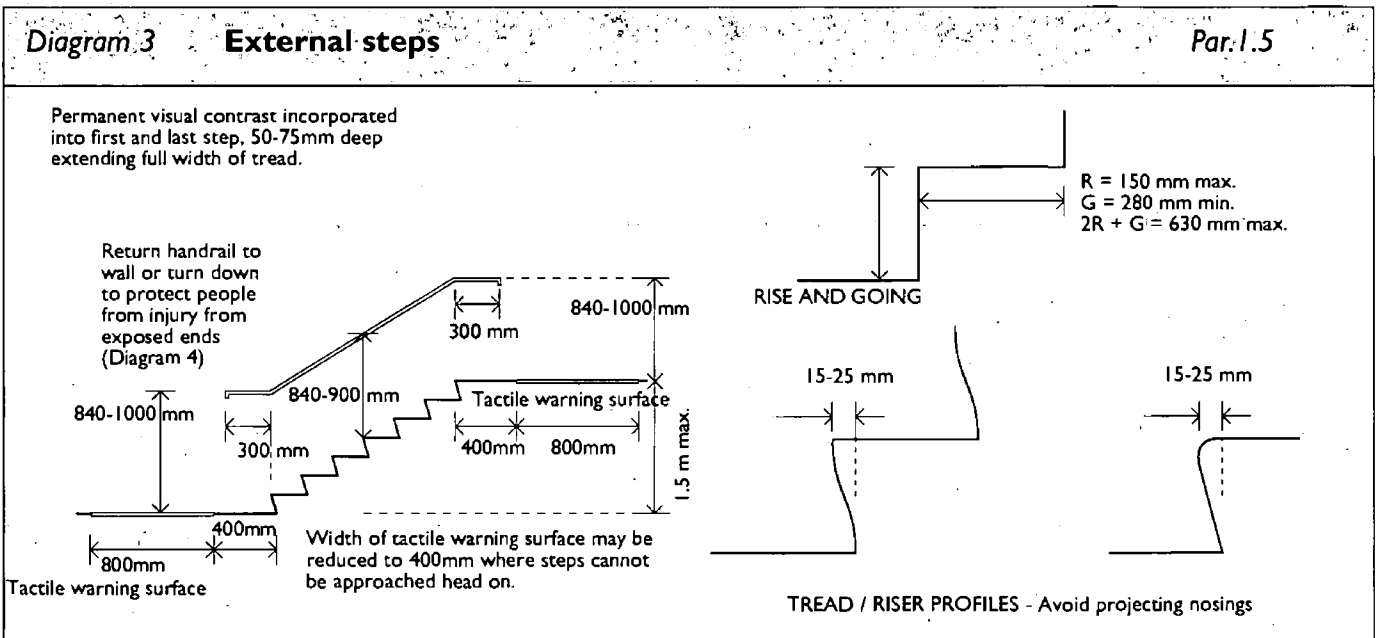

Access into a Building

1.7 An accessible entrance should be so designed and constructed that :

- (a) the doorway provides a *minimum* clear opening width of not less than 800 mm. Double doors should include at least one leaf which provides a *minimum* clear opening width of not less than 800 mm;
- (b) there is an unobstructed space of at least 300 mm on the side next to the leading edge of a single leaf door;
- (c) each leaf of a door incorporates, where feasible and practicable, a glazed vision panel extending from 900 mm to 1.5 m above the finished floor level;
- (d) any single pane fully glazed door leaf or fixed panel is permanently marked within the pane 1200 mm to 1500 mm above floor level so as to visually indicate the presence of the leaf or panel;
- (e) any door has ironmongery which is suitable for operation by people with disabilities; and

- (f) any door fitted with a self-closing device is suitable for operation by people with disabilities.

In general, revolving doors are not suitable for use by people with disabilities. *Diagrams 5 and 6* illustrate the guidance on doors.

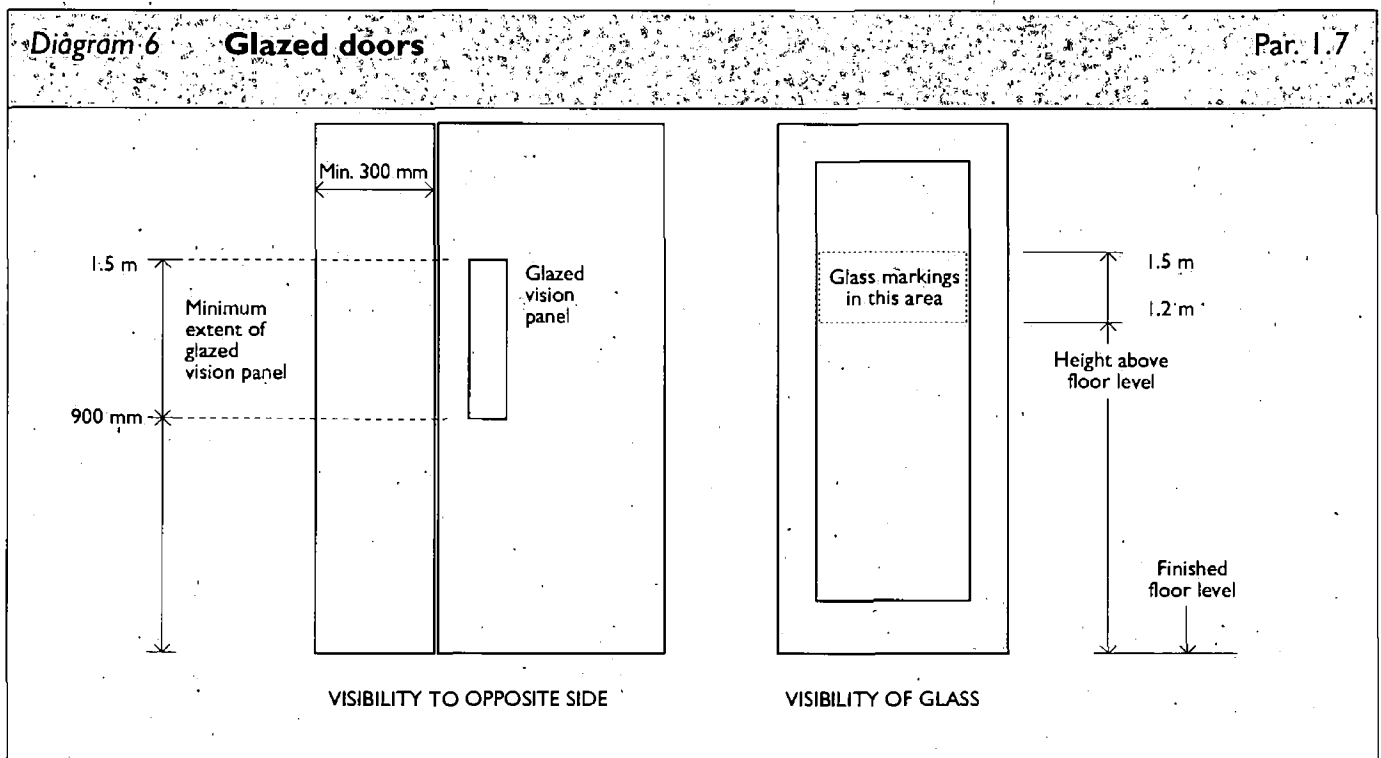
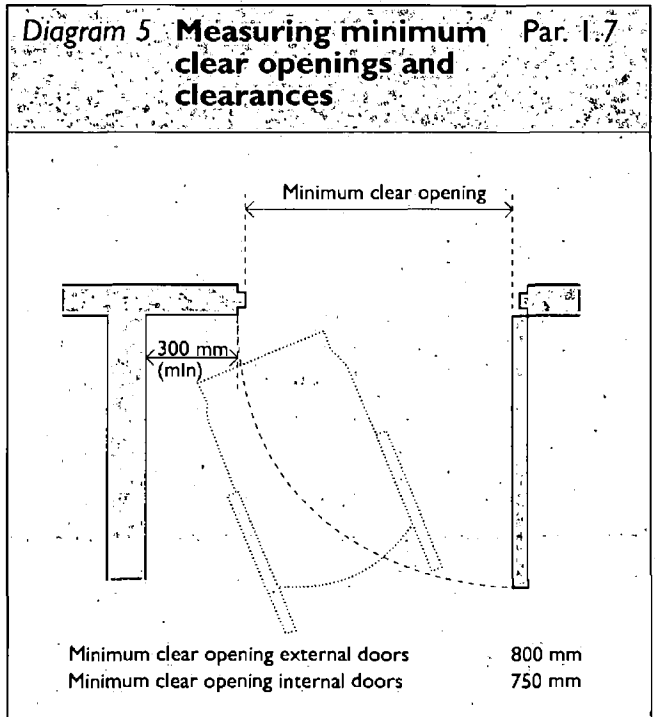
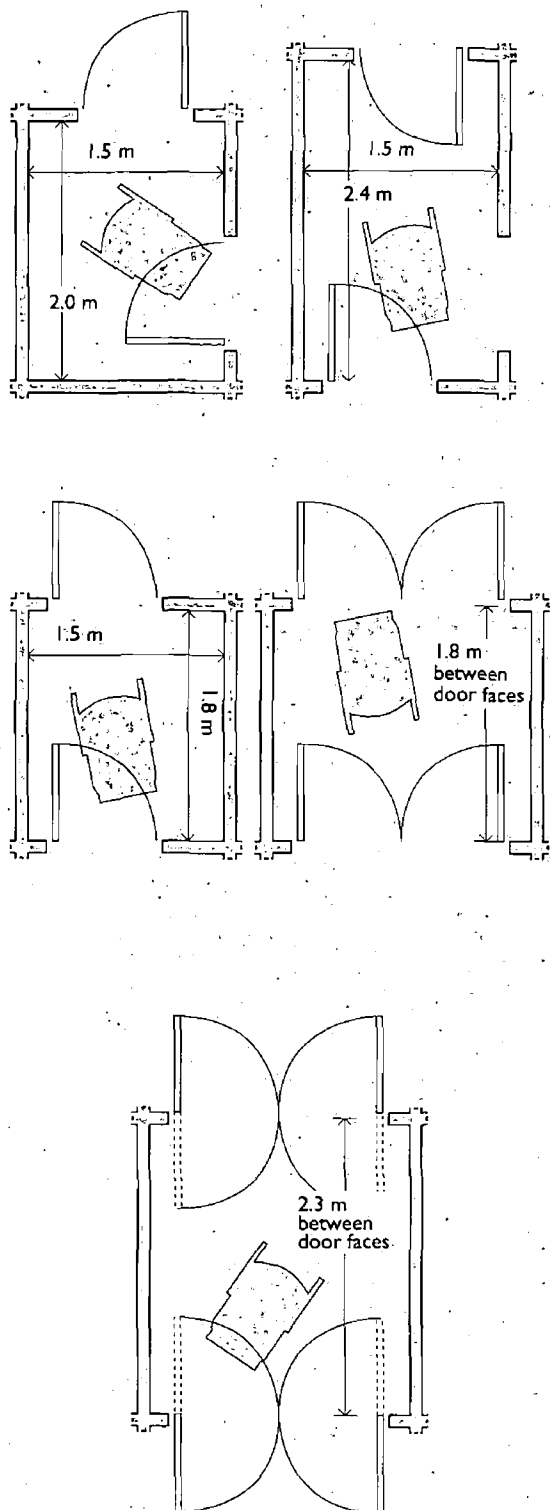

Diagram 7 Entrance lobbies Par. 1.8



1.8 Entrance lobbies should be so designed and constructed that there is sufficient space to enable a wheelchair user, and a person assisting the wheelchair user, to move clear of one door before using the next one while allowing space for a person to pass in the opposite direction. Examples of lobbies of suitable dimensions are shown in *Diagram 7*.

Circulation within a Building

1.9 Internal doors should be so designed and constructed that:

- (a) they provide a *minimum* clear opening width of not less than 750 mm. Double doors should include at least one leaf which provides a *minimum* clear opening width of not less than 750 mm;
- (b) there is an unobstructed space of at least 300 mm on the side next to the leading edge (see par. 1.18 for specific guidance in relation to hotel and other guest bedrooms);
- (c) each leaf of a door in a corridor or passageway incorporates, where feasible and practicable, a glazed vision panel extending from 900 mm to 1.5 m above the finished floor level;
- (d) any single pane fully glazed door leaf or fixed panel is permanently marked within the area 1200 mm to 1500 mm above floor level, so as to visually indicate the presence of the door or panel;
- (e) the ironmongery is suitable for operation by people with disabilities; and
- (f) any door fitted with a self-closing device is suitable for operation by people with disabilities.

Diagrams 5 and 6 illustrate the guidance on doorways and glazed panels.

1.10 A corridor or passageway accessible to wheelchair users should have a clear unobstructed width of at least 1.2 m. Where a stairway crosses over a circulation route, suitable precautions should be taken to ensure that any part of the area under

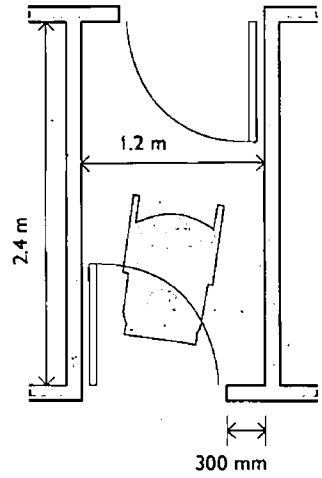
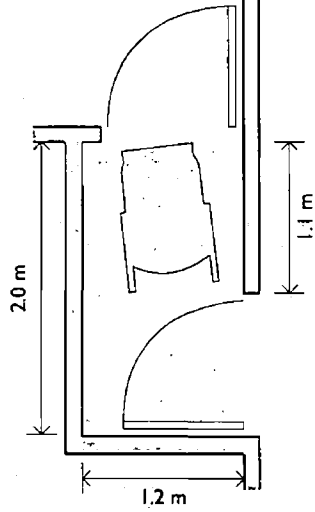
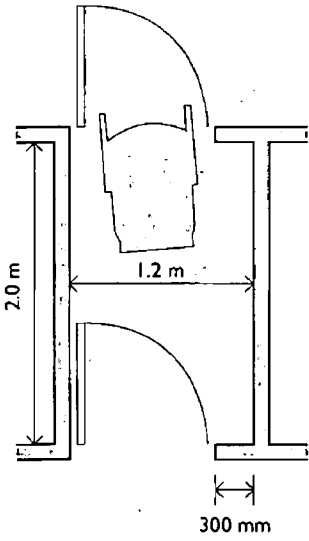

(a) 1.2 m WIDE LOBBY

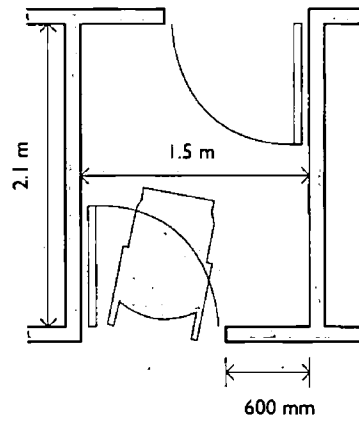
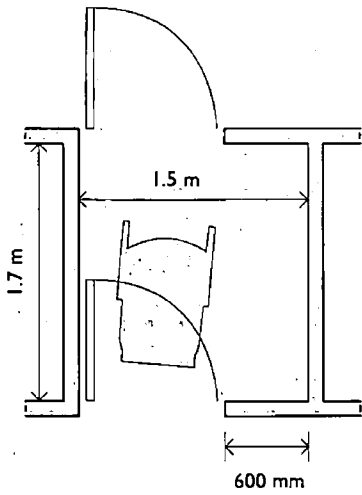

(b) 1.5 m WIDE LOBBY

the stairway with a height lower than 2.0 m cannot be used for circulation purposes.

1.11 Internal lobbies should be so designed and constructed that there is sufficient space to enable a wheelchair user and the person assisting the wheelchair user, to move clear of one door before using the next one. Examples of internal lobbies of suitable dimensions are shown in *Diagram 8*.

1.12 A suitable passenger lift should be provided to any storey above or below the entrance storey which:

- (a) in a two storey building has a nett floor area per floor of more than 280 m²; or
- (b) in a building of more than two storeys has a nett floor area per floor of more than 200 m².

In calculating nett floor area, the areas of all parts of a storey which can be reached from the same entrance to the storey (including any flats) should be added together, whether they are in more than one part of the same storey or used for different purposes. The area of any vertical circulation, common sanitary accommodation and maintenance areas in the storey should not be included.

A suitable passenger lift should also be provided to each storey above or below the entrance storey which provides access to flats when,

- (i) the total number of flats accessed from all such storeys exceeds eight, or
- (ii) the number of flats with entrance levels more than 10 m above the level of the main entrance to the building exceeds two.

1.13 Where a passenger lift is provided :

- (a) there should be a clear landing at least 1.5 m wide and at least 1.5 m long in front of every entrance to the lift;
- (b) the lift door or doors should have a clear opening width of at least 800 mm;
- (c) the width of the lift car should be at least 1.1 m and the length at least 1.4 m;
- (d) the controls in the lift car and the controls at each landing should be at a height of not less than 900 mm and not more than 1.2 m above

the car floor and the landing respectively. Controls should not be located in corners and should be at least 500 mm from any wall or projecting surface;

- (e) suitable tactile indicators to indicate floor numbers should be provided on or adjacent to lift buttons within the lift car and on the landing;
- (f) the lift car should provide both visual and voice indication of the floor reached if it serves more than three floors;
- (g) lift doors should stay open for at least eight seconds;
- (h) a half-length mirror should be installed to provide a wheelchair user with a rearview to safely reverse out from the liftcar.

Diagram 9 illustrates a suitable passenger lift.

1.14 Where a building is not required to be provided with a lift in accordance with par. 1.12, at least one internal stairs, satisfying the needs of ambulant disabled people, should be provided. It should be designed and constructed in accordance with the guidance set out for a stepped approach in par. 1.5, except for the following:

- (a) the rise of a flight between landings should not exceed 1.8 m; and
- (b) the rise and going of each step should be uniform, with the rise not greater than 175 mm and the going not less than 250 mm.

A suitable continuous handrail should be provided on each side of flights and landings. This should be in accordance with the guidance given in par. 1.6.

Diagram 10 illustrates the guidance on internal stairs.

1.15 Where internal graded or sloped circulation routes are provided, the design considerations are similar to those for sloped approaches.

1.16 See Technical Guidance Document K for guidance on the provision of guarding.

Use of Facilities in a Building

1.17 Each storey of a building should be so designed and constructed as to allow for

Permanent visual contrast incorporated into first and last step, 50-75mm deep extending full width of tread.

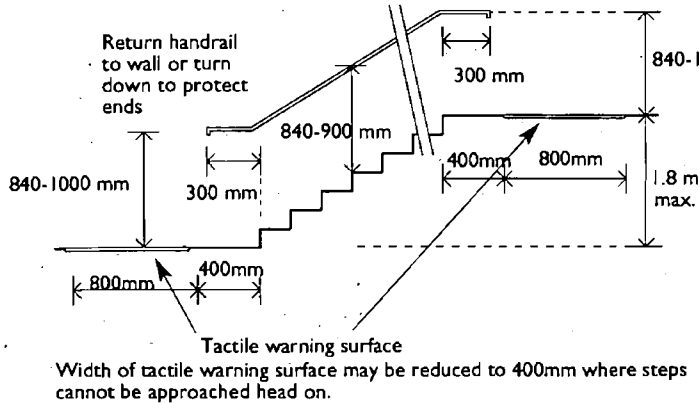

R = 175 mm max.
G = 250 mm min.
2R + G = 630 mm max.

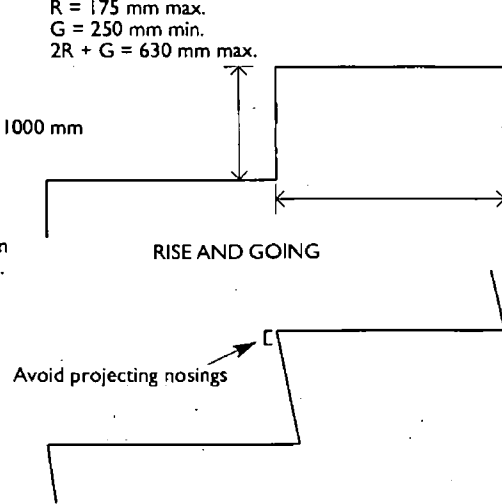

independent circulation by people with disabilities and independent access to the range of services and facilities provided on that storey. Where a change of level within a storey of a building is necessary because of site constraints or design considerations, either -

- (a) suitable means of access should be provided between the levels by graded or sloped access or by means of a passenger lift or platform lift, or
- (b) the same range of services and facilities which is available to able-bodied users of the storey should be available and accessible on the level to which independent access for people with disabilities is available.

Careful attention should be given to the selection and location of ironmongery, taps, light switches, power points, communication facilities etc. so that they can be operated by light pressure and without undue stretching, or stooping, by wheelchair users and the ambulant disabled.

Hotel and Other Guest Bedrooms

1.18 The requirement of access for people with disabilities to bedrooms in hotel and other guest accommodation may be regarded as being met if:

- (a) one guest bedroom out of every twenty, or part thereof, of guest bedrooms is suitable in terms of size, layout and facilities for independent use by a wheelchair user,
- (b) the same proportion of such bedrooms should have en suite sanitary accommodation as is provided in other bedrooms, and
- (c) the entrance door to a guest bedroom, which is designed for independent use by a wheelchair user, complies with the guidance in par. 1.9 (while other bedroom doors should have a clear opening width of 750 mm, the requirement to provide a 300 mm space at the side of the door would not apply).

Diagram 11 illustrates an example of an accessible bedroom. For guidance on sanitary conveniences see Section 2.

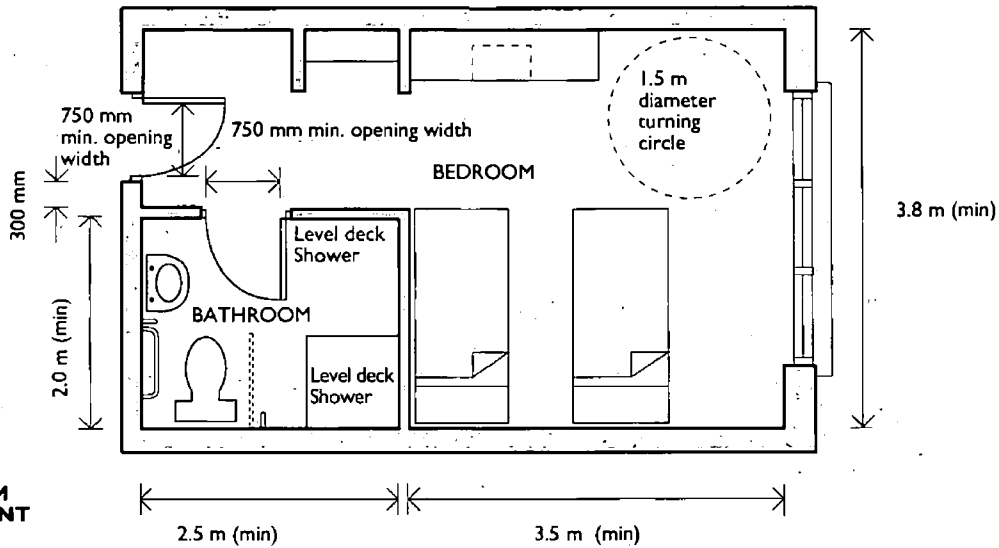

BATHROOM ARRANGEMENT

In larger bathrooms, a bath may be provided in addition to a level deck shower. Where more than one accessible bathroom en suite is provided, a bath with appropriate grabrails and a 400mm wide ledge at the end may be used instead of a level deck shower in up to half such bathrooms.

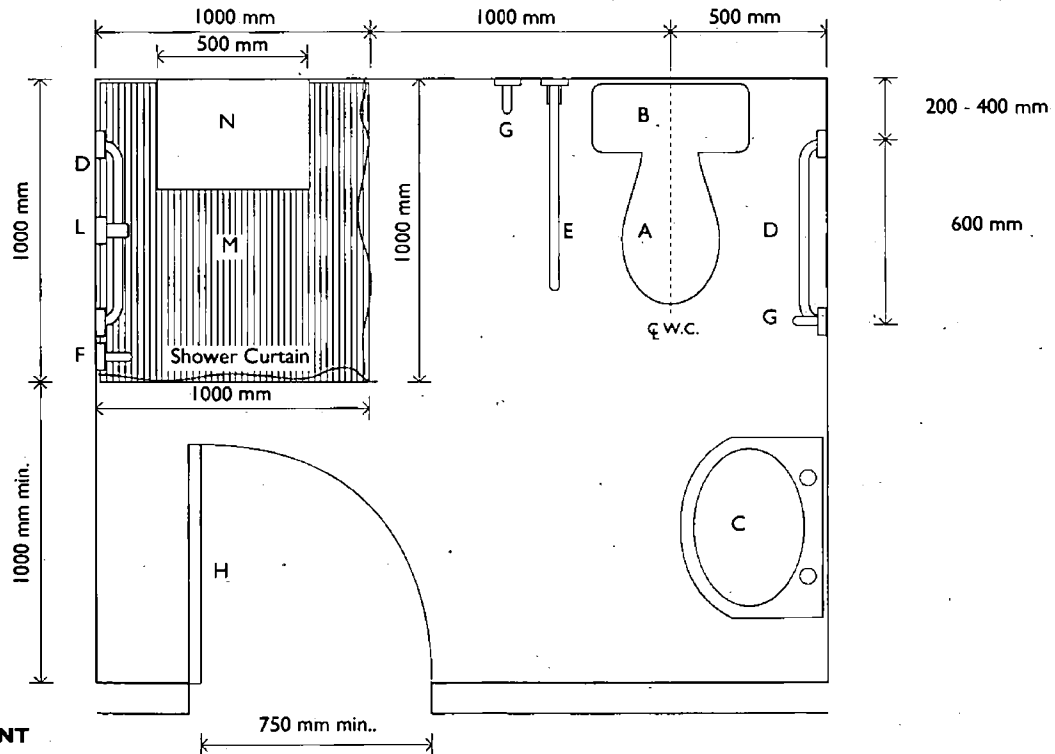

SHOWER ARRANGEMENT

- | | | | |
|---|------------------------------|---|----------------------------|
| A | W.C. PAN (450 - 460 mm high) | H | DOOR |
| B | BACK REST / CISTERN | J | PAPER HOLDER |
| C | FULL SIZE HAND BASIN | K | TOWEL DISPENSER |
| D | HORIZONTAL GRABRAIL | L | SHOWER CONTROLS |
| E | FOLDING GRABRAIL (optional) | M | LEVEL DECK SHOWER FACILITY |
| F | VERTICAL GRABRAIL | N | FLIP-DOWN SEAT |
| G | VERTICAL GRABRAILS | | |

Section 1b: Dwellings

1.19 The guidance in Section 1b applies to new dwellings:

Approach to a dwelling

1.20 The *minimum* clear opening width of at least one point of access at the boundary of the dwelling plot should be 800 mm.

1.21 The main dwelling entrance, should be accessible to wheelchair users. There should be a clear area at least 1.2 m wide and at least 1.2 m deep in front of every such entrance. Where this is not practicable, an alternative entrance should be accessible. The approach to this entrance from the point of access referred to in par. 1.20 should be suitable for use by wheelchair users. Alternatively, the approach suitable for use by wheelchair users may be provided from a point within the curtilage of the dwelling plot where a visitor can conveniently alight from a vehicle, where

- (a) the distance between the point of access to the site and the nearest entrance is greater than 30 m, or
- (b) the plot gradient is such that the relative finished levels at the dwelling entrance and the point of access to the dwelling site do not allow for the provision of the appropriate level, sloped or ramped approach.

The approach should have a clear unobstructed width of at least 900 mm and have a firm surface which is suitable for wheelchair use and reduces the risk of slipping. It should be level (slope not more than 1:50) or, where plot gradients do not allow this, gently sloping.

A sloped approach should have the flattest gradient achievable. Where the gradient is steeper than 1:20, the maximum length between level landings should be 10 m. Where the gradient is between 1:20 and not exceeding 1:15 the maximum length between level landings should be 10 m. Where the gradient is between 1:15 and 1:12, the maximum length between level landings should be 6 m.

The approach may, in whole or in part, form part of an onsite driveway. Where this occurs, the driveway

should be at least 3 m wide so as to allow adequate unobstructed width at parked cars.

A raised kerb, at least 75 mm high, should be provided on any open side where the adjacent ground is not graded to the approach.

See Technical Guidance Document K for guidance on the provision of guarding.

1.22 Where it is not practicable to provide the required level or sloped approach to the dwelling entrance from either the point of entry to the dwelling plot or from a point within the curtilage of the plot where a visitor can alight from a vehicle, a stepped approach may be used. This may arise

- (a) where the gradient between the point of entry to the dwelling plot, or a point within the curtilage where a person can alight from a vehicle, and the dwelling entrance is steeper than 1:15;
- (b) where there is insufficient space between the point of entry to the dwelling plot and the dwelling entrance to provide for slopes and landings because of the need to conform to the existing building line or for other planning requirements; or
- (c) where the dwelling entrance is at other than the ground floor level of the building, e.g. duplex buildings or the like.

Guidance on the approach to apartment blocks and the like is given in Section 1a.

Where a stepped approach is used, it should be suitable for use by ambulant disabled people and should comply with the following:

- (a) it should have a clear unobstructed width of 800 mm,
 - (b) the rise of a flight between landings should be not more than 1.8 m,
 - (c) it should have top and bottom and, if necessary, intermediate landings, each of which should be at least 900 mm long,
 - (d) steps should have suitable tread/nosing profiles (see *Diagram 3*) and the rise of each step should be uniform and not more than 150 mm,
 - (e) the going of each step should be uniform and not less than 280 mm, which, for tapered
-

treads, should be measured at a point 270 mm from the "inside" of the flight, and

- (f) there should be a suitable continuous handrail, as detailed in par. 1.6 and *Diagram 4*, on both sides of the flights and intermediate landings, if the flight comprises three or more risers. Where a shallow stepped approach with goings at least 750 mm long is used, handrails need not be provided.

See Technical Guidance Document K for guidance on the provision of guarding.

Access into a Dwelling

1.23 Where the approach to a dwelling entrance is level, or sloped, i.e. free of steps, or, in the case of apartment blocks or the like, is provided with a suitable passenger lift in accordance with par. 1.12, and there is at least one habitable room at entry level, the entrance should be suitable for wheelchair access. In this case,

- (a) the entrance should be provided with a level entry, i.e. with maximum threshold height of 15 mm, and
(b) the *minimum* clear opening width of the entrance door should be 775 mm.

1.24 Where a level entry is provided, regard should be had to the requirements of the Regulations generally, particularly in relation to resistance to weather and ground moisture. Guidance on the issues involved in the provision of level entry can be found in the publication "Accessible Thresholds in New Housing".

1.25 Where a stepped approach is used (see par. 1.22) or where the entrance storey does not contain at least one habitable room, one or more steps may be used at the dwelling entrance. Steps externally should comply with the guidance given in par. 1.22. If the steps are inside a building, they should comply with the guidance given in par. 1.30 below.

1.26 Equipment adjacent to the entry intended to assist in gaining entry, e.g. doorbells, entry phones, should be located at a height between 900 mm and 1200 mm above floor level.

Circulation within a Dwelling

1.27 Corridors, passageways and doors to habitable rooms in the entrance storey or, where there is no habitable room at this level, in the storey containing the main living room, should be sufficiently wide and free of stepped changes of level so as to allow convenient circulation by people with disabilities. Corridors and passageways should have a *minimum* unobstructed width of 900 mm. Local permanent obstructions, such as radiators, may be allowed, provided that the unobstructed width in those areas is at least 750 mm. Where a stepped change of level is provided, e.g. because of the slope of the site, it should be located so that at least one habitable room can be accessed from the accessible entrance without the need to negotiate the step(s).

1.28 Doors to accessible habitable rooms should be so designed and constructed that the *minimum* clear opening width, in relation to the adjacent unobstructed corridor width, complies with the following:

Minimum clear opening width (mm)	Minimum unobstructed corridor width (mm)
750	1200 (900 if approached head-on)
775	1050 (900 if approached head-on)
800	900

The length of unobstructed corridor complying with the *minimum* width requirement specified should be at least 1200 mm.

Saddleboards, where provided, should be bevelled with maximum upstand of 10 mm.

Doors to rooms which can only be accessed by the use of steps or stairs, may have a *minimum* clear opening width of 750 mm, irrespective of the adjacent unobstructed corridor width.

Diagram 12 illustrates the guidance on internal doors, corridors and passageways for convenient wheelchair use.

1.29 Door handles should be located at a height of 900 mm to 1200 mm above floor level. Electric light switches should be located at a similar height.

1.30 Where there is no habitable room at entry level, the stairway providing access to the storey containing the main living room should comply with the following:

- (a) it should have a clear unobstructed width of 800 mm,
- (b) the rise of a flight between landings should be not more than 1.8 m,

- (c) it should have top and bottom and, if necessary, intermediate landings, each of which should be at least 900 mm long.
- (d) the rise of each step should be uniform and not more than 175 mm,
- (e) the going of each step should be uniform and not less than 250 mm, which, for tapered treads, should be measured at a point 270 mm from the "inside" of the flight, and
- (f) there should be a suitable continuous handrail, as detailed in par. 1.6 and *Diagram 4*, on each side of the flights and intermediate landings, if the flight comprises three or more risers.

Diagram 12 Corridors, passages and internal doors in dwellings Par. 1.28

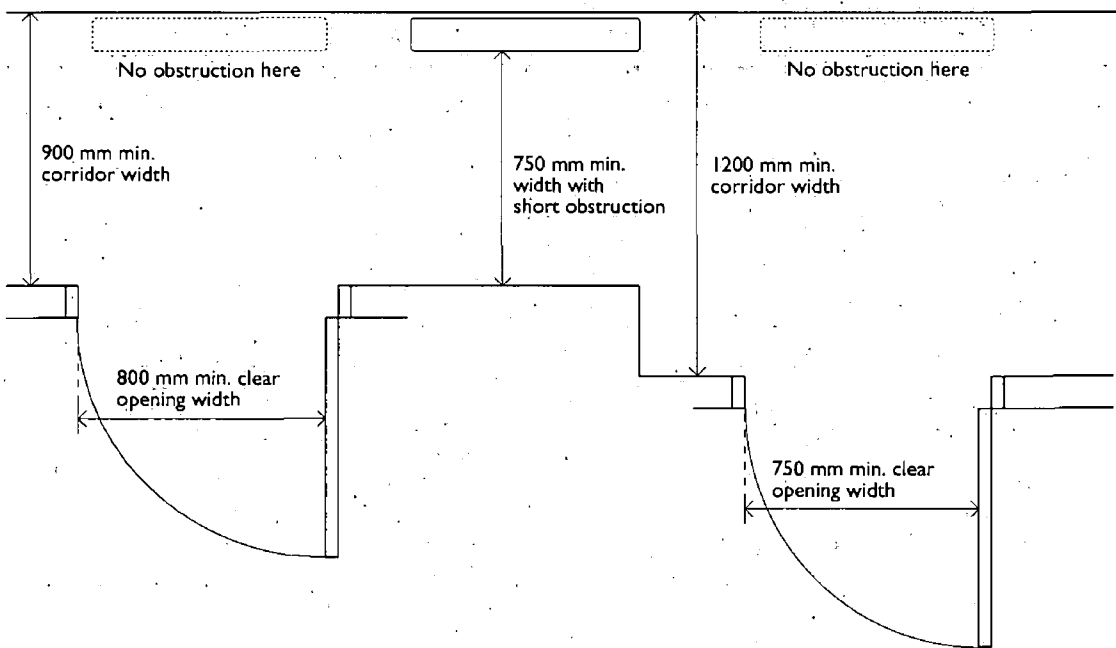

Sanitary Conveniences

Sanitary conveniences	M2	If sanitary conveniences are provided in a building, adequate provision shall be made for people with disabilities
-----------------------	----	--

Section 2a: Buildings other than dwellings

2.1 The guidance in Section 2a applies to buildings other than dwellings.

2.2 Provision for sanitary accommodation for people with disabilities should be made on the same basis as provision is made for other users of the building, i.e. if sanitary accommodation is only provided for staff, then provision should be made for staff with disabilities (whether or not any member of the present staff is disabled), whereas, if sanitary accommodation is provided for customers or visitors to the building, provision should also be made for customers or visitors with disabilities.

In case of places of work, designers should have regard to the Safety, Health and Welfare at Work (General Application) Regulations, 1993 (S.I. No. 44 of 1993).

2.3 The number and location of WC cubicles required in a building to meet the needs of wheelchair users and other people with disabilities will be dictated by the nature of the building, the size of the building, the number of people who will use the building and the ease of access. Where one or two WCs are sufficient, they should be unisex and at least one should be wheelchair accessible. In buildings or parts of buildings, which are open to the public, one unisex WC suitable for use by wheelchair users of either sex and approached separately from other sanitary accommodation should be provided as a *minimum*. In buildings intended for use by staff only, provision for people with disabilities may be made in the context of the traditional separate provision for men and women, or as unisex provision approached separately from other sanitary accommodation. Sanitary accommodation for people with disabilities should be provided in a convenient and accessible part of a building to which wheelchair users have independent access.

2.4 Where independent access to storeys, above or below the entrance storey, is not available for wheelchair users, i.e. if access is by stairway only, a

unisex WC suitable for use by wheelchair users of either sex should be located on the entrance storey except where the entrance storey contains only the entrance and vertical circulation areas. In such cases, the provision of a WC accessible to wheelchair users is not mandatory. However, in every such building, provision for ambulant disabled people should still be made (see par. 2.6).

2.5 To be suitable for use by a wheelchair user, a WC cubicle should have adequate space:

- to allow for necessary wheelchair manoeuvre, and
- to allow for transfer onto the WC, to allow a helper to assist in the transfer, and to have facilities for handwashing within reach of the WC.

Where more than one unisex WC cubicle, suitable for use by a wheelchair user, is provided, then handing of the internal layout will provide for both left and right hand transfer onto a WC.

Diagram 13 illustrates the type of WC facilities required by a wheelchair user. A distance of 750 mm from the back wall to the front of the WC pan allows the wheelchair seat to be parallel with the toilet seat, so that the wheelchair can be reversed against the wall and the person using the toilet does not have to manoeuvre both sideways and also backwards to get into the seat.

A distance of 200 mm from the front of the WC pan to the vertical grab rail is also desirable so that a person on the toilet does not have to reach backwards for support at the same time as transferring back into the wheelchair. At the same time, the person sitting on the toilet should be able to lean forward and wash their hands in the basin, and insert or take out the wash-hand-basin waste plug. The 50 mm maximum dimension from grab rail to wash-hand-basin edge is so as to keep the wash-hand-basin as close as is reasonably practicable to the WC pan.

A distance of 450-500 mm from WC pan to the wall ensures enough space for the wheelchair on the opposite side of the WC, in the given 1.5 m overall dimension.

The desirable length of a grab rail is 600 mm so as to allow ease of grasping.

A distance of 800 mm from floor to washbasin is to optimise the ease of getting one's knees below the basin while not having the basin too high so as to make it difficult to reach the waste.

2.6 Where provision for the ambulant disabled is required (see par. 2.4), this can be achieved by the provision of suitable grabrails in conventional WC cubicles. At least one such cubicle should be provided in each room containing sanitary conveniences.

Diagram 14 illustrates a WC for ambulant disabled people.

2.7 In hotels and other guest accommodation, where en suite sanitary accommodation is provided in bedrooms suitable for independent use by a wheelchair user (see par. 1.18), such en-suite accommodation should also be suitable for independent use by a wheelchair user. Where en-suite sanitary accommodation is not provided 'unisex' sanitary accommodation suitable for use by a wheelchair user should be provided.

En suite provision should include level deck shower unit. In larger bathrooms, provision may also be made for a bath. Where accessible en-suite sanitary accommodation is provided in more than one bedroom, a bath may be provided instead of a level deck shower in up to half such bedrooms (see *Diagram 11*). In all other areas of hotels etc., sanitary accommodation in accordance with pars. 2.2 to 2.6 should be provided.

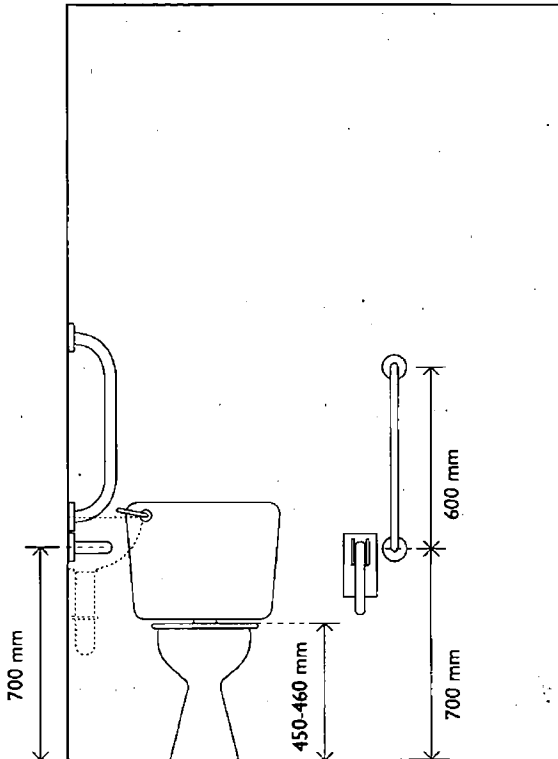

CROSS SECTION

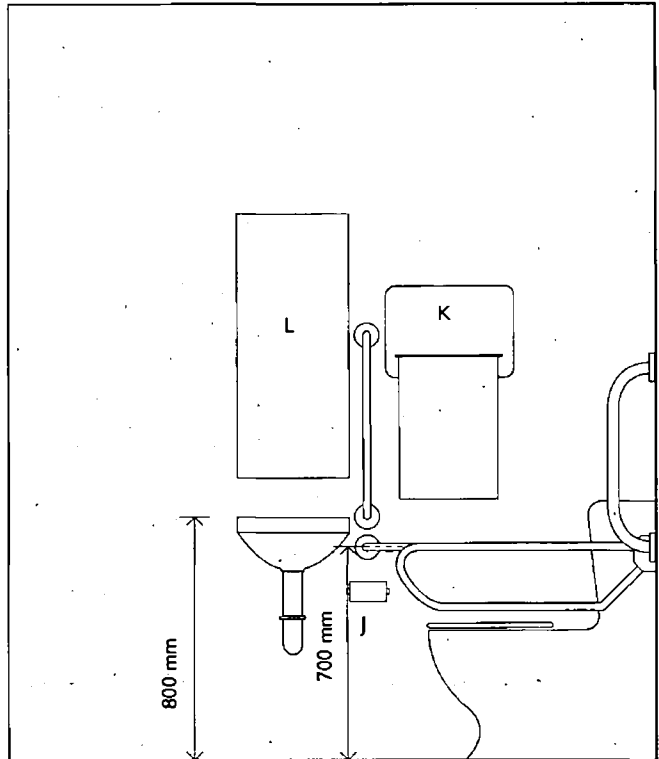

LONGITUDINAL SECTION

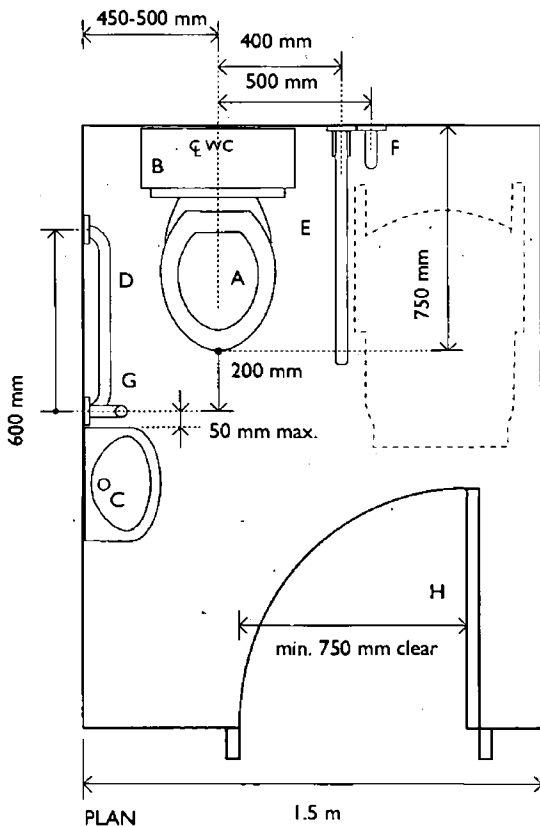

PLAN

- A SPECIAL W.C. PAN
- B BACK REST / CISTERN
- C RINSE BASIN
- D HORIZONTAL GRABRAIL
- E FOLDING GRABRAIL (optional)
- F VERTICAL GRABRAIL
- G VERTICAL GRABRAIL
- H DOOR
- J PAPER HOLDER
- K TOWEL DISPENSER
- L MIRROR

NOTES

(a) Cubicle door should be on 1.5m side, opposite position for wheelchair.

(b) Layout shown is for right hand lateral transfer. Where more than one toilet is being provided they should be handed. In this case the door should also be handed.

(c) In cases where a low level cistern is not used, a back rest should be provided.

(d) All dimensions are finished dimensions (see par. 0.7)

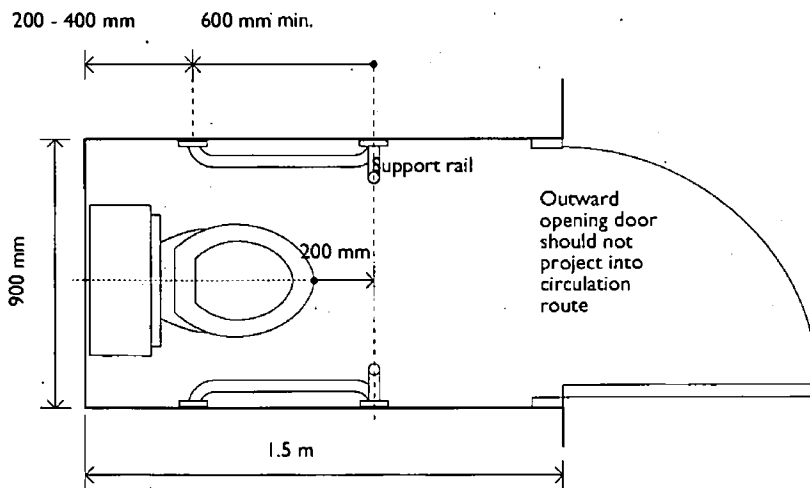
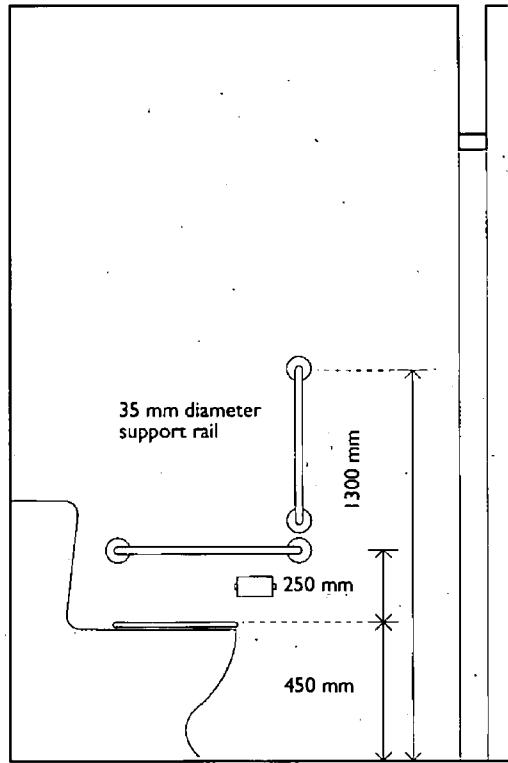

Section 2b: Dwellings

2.8 The guidance in Section 2b applies to new dwellings.

2.9 A WC should be provided at entry level or, where there is no habitable room at this level, in the storey containing the main living room. At entry level, the WC should be so located that it can be accessed from the accessible entrance and from at least one habitable room without the need to negotiate steps.

The WC should be located in a bathroom or separate WC compartment, the layout of which should be designed to facilitate access to, and use of, the WC by persons with disabilities. A clear space 750 mm by 1200 mm, accessible by wheelchair users, should be available adjacent to the WC so as to facilitate sideways transfer from the chair to the WC.

In general, the size and layout of the bathroom or WC compartment, and the positioning of the door, should be such that a wheelchair can be fully contained within the compartment and the door closed with the wheelchair inside. *Diagram 15* shows two examples of alternative layouts for WC compartments which illustrate the level of provision which is considered generally acceptable.

However, in the case of certain smaller dwellings, WC compartments which, while providing for the necessary clear space to facilitate for sideways transfer, cannot fully accommodate a wheelchair or do not facilitate the compartment door to be closed with the wheelchair inside, may be acceptable. This level of provision should only be considered where the area of the storey where the WC is located is less than 45 m². *Diagram 16* shows two examples of possible layouts for such compartments.

Guidance regarding the clear opening width of internal doors (see par. 1.28) applies to the door of the WC compartment. Use of a door opening wider than the *minimum*, an outward opening door, a folding door or a sliding door will generally assist in facilitating wheelchair access. The choice of door type and location should be such as not to pose undue hazard on a circulation route or be otherwise dangerous in use.

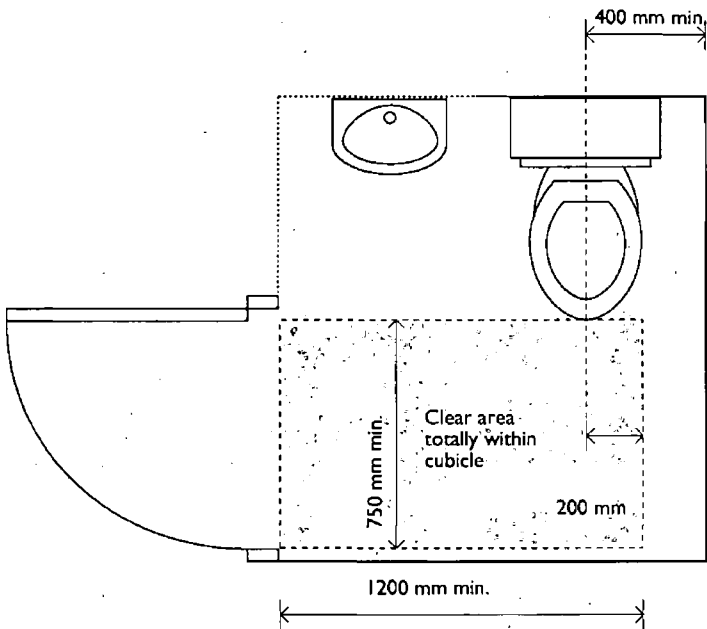

OPTION [A]

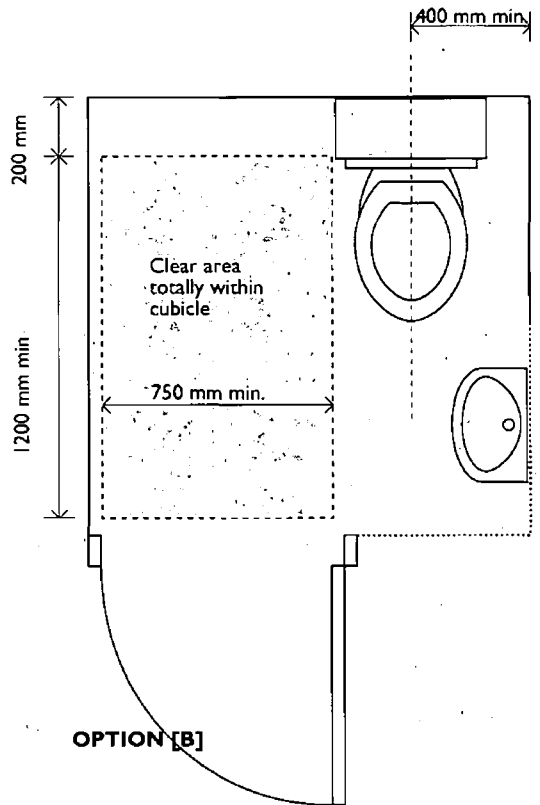

OPTION [B]

NOTE: Washbasin may be located either within the space containing the WC or in an area adjacent to that space (see reg. G2(2)). The washbasin should be located so as not to impede access.

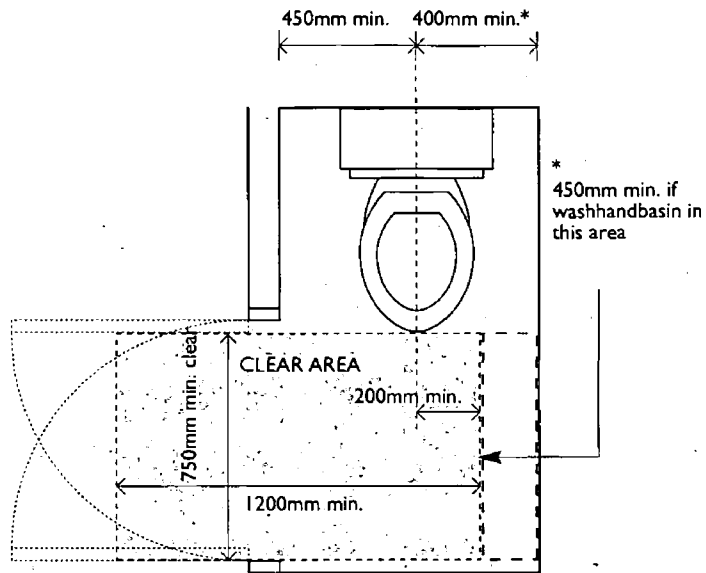

[A] WHEELCHAIR CLEAR AREA PERPENDICULAR TO CENTRE LINE OF WC

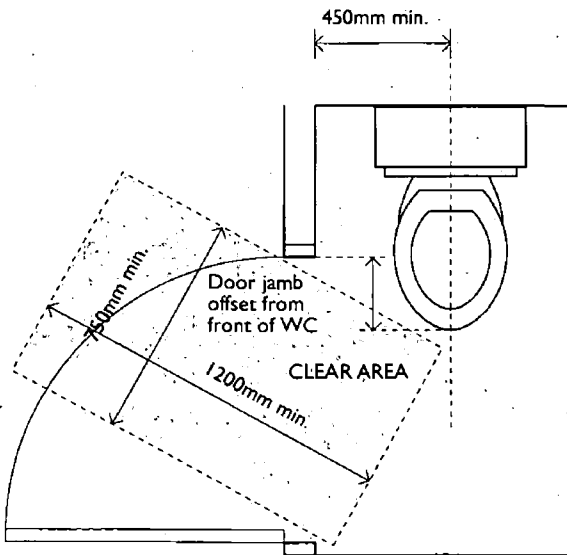

Door jamb offset from front of WC	Minimum clear opening width of door
250mm	900mm
200mm	850mm
150mm	800mm
100mm	775mm
0mm	750mm

Note: Clear opening width of door should also comply with par. 1.28.

[B] WHEELCHAIR CLEAR AREA AT ANGLE TO CENTRE LINE OF WC

Audience or Spectator Facilities

Audience or spectator facilities	M3	If a building contains fixed seating for audience or spectators, adequate provision shall be made for people with disabilities.
----------------------------------	----	---

3.1 It is a functional characteristic of certain types of buildings, theatres, cinemas, concert halls; lecture theatres, sports stadia and the like, that audience or spectator accommodation is provided at several levels and frequently this necessitates the use of tiered or sloping floors. While ambulant disabled people should have access to all levels of such premises the requirement for access for wheelchair users may be regarded as being met, notwithstanding par. 1.12, if independent access is available to sufficient wheelchair spaces in selected areas which afford good viewing conditions and provided there are available and accessible to people in those areas facilities such as bars, WC's, etc. similar to those available to other users of the premises.

3.2 Areas where wheelchair spaces are located should be integrated with areas provided for the general public and wheelchair users should be able to sit with their companions. A wheelchair space may be one which is kept clear or one which can readily be provided for the occasion by removing a seat.

3.3 A wheelchair space can be provided by a clear space with a width of at least 900 mm and a depth of at least 1.4 m.

3.4 The *minimum* number of wheelchair spaces should be 6 or 1/50th (whichever is the greater) of the seating capacity where the seating capacity is not more than 1,000 and 20 or 1/100th (whichever is the greater) of the seating capacity where the seating capacity is more than 1,000. Where a building contains several auditoria, e.g. a multi-screen cinema or a block of lecture theatres and the like, the *minimum* requirement applies to each auditorium.

3.5 In certain types of buildings, such as theatres, cinemas, concert halls, meeting and conference rooms, places of religious worship and the like, the provision of aids to communication is essential to the satisfactory use by people who have a hearing impairment. Suitable aids would include loop induction or infra-red based systems.

3.6 The above guidelines relate specifically to the provision to be made for people with disabilities

attending as spectators or members of an audience. As with other buildings provision should also be made so that people with disabilities can have access to other parts of these buildings and use the facilities there e.g. stages, changing rooms, etc.

Access to the Historic Environment - Meeting the Needs of Disabled People, Lisa Foster, Donhead Publishing Ltd., Lower Coombe, Donhead St. Mary, Shafresbury, Dorset, SP7 9LY, England (1997)

Building for Everyone - Access and Use for all Citizens (1998 edition), National Disability Authority, 25 Clyde Road and Access Service, Comhairle, 44 Nth. Great George's Street, Dublin 1

European Institute for Design and Disability Annual, 1999. Available from National College of Art & Design, 100 Thomas Street, Dublin 8

Designing for Accessibility - an introductory guide by Tessa Palfreyman and Stephen Thorpe 1993

Designing for People with Sensory Impairments Stephen Thorpe Access Committee for England, 1986

Accessible Thresholds in New Housing, Guidance for House Builders and Designers (1999) Department of Environment, Transport and the Regions. The Stationery Office, The Publications Centre, PO Box 276, London SW8 5DT

Safety, Health and Welfare at Work (General Application) Regulations, 1993 (S.I. No. 44 of 1993)

IS EN 81 - 1 : 99 Safety rules for the construction and installation of lifts Part 1 : Electric lifts

IS EN 81 - 2 : 99 Safety rules for the construction and installation of lifts Part 2 : Hydraulic lifts

BS 5655 Lifts and service lifts: Part 5 : 1989 Specifications for dimensions for standard lift arrangements

BS 5655 Lifts and service lifts: Part 7 : 1983 Specifications for manual control devices, indicators and additional fittings AMD 4912

BS 5776 : 1996 Specifications for powered stairlifts

BS 6440 : 1983 Code of practice for powered lifting platforms for use by disabled persons
